



Co-funded by the European Union



german
cooperation
DEUTSCHE ZUSAMMENARBEIT



Norwegian Embassy
Islamabad



SURGICAL INSTRUMENTS MANUFACTURING TECHNICIAN



© TVET SSP

LEARNER GUIDE

National Vocational Certificate Level 3

Version 1 - May, 2019



Implemented by
giz Deutsche Gesellschaft
für Internationale
Zusammenarbeit (GIZ) GmbH

Published by

National Vocational and Technical Training Commission
Government of Pakistan

Headquarter

Plot 38, Kirthar Road, Sector H-9/4, Islamabad, Pakistan
www.navttc.org

Responsible

Director General Skills Standard and Curricula, National Vocational and Technical Training Commission
National Deputy Head, TVET Sector Support Programme, Deutsche Gesellschaft für Internationale Zusammenarbeit (GIZ) GmbH

Layout & design

SAP Communications

Photo Credits

TVET Sector Support Programme

URL links

Responsibility for the content of external websites linked in this publication always lies with their respective publishers. TVET Sector Support Programme expressly dissociates itself from such content.

This document has been produced with the technical assistance of the TVET Sector Support Programme, which is funded by the European Union, the Federal Republic of Germany and the Royal Norwegian Embassy and has been commissioned by the German Federal Ministry for Economic Cooperation and Development (BMZ). The Deutsche Gesellschaft für Internationale Zusammenarbeit (GIZ) GmbH in close collaboration with the National Vocational and Technical Training Commission (NAVTTTC) as well as provincial Technical Education and Vocational Training Authorities (TEVTAs), Punjab Vocational Training Council (PVTC), Qualification Awarding Bodies (QABs)s and private sector organizations.

Document Version

May, 2019

Islamabad, Pakistan

SURGICAL INSTRUMENTS MANUFACTURING TECHNICIAN



© TVET SSP

LEARNER GUIDE

National Vocational Certificate Level 3

Version 1 - May, 2019

Introduction

Welcome to the Learner's Guide for the Surgical instruments Manufacturing Technician expert program. It will help you to complete the program and to go on to pursue further study or go straight into employment.

The Surgical instruments Manufacturing Technician expert program is to engage young people with a program of development that will provide them with the knowledge, skills and understanding to start this career in Pakistan. The program has been developed to address specific issues, such as the national, regional and local cultures, the manpower availability within the country, and meeting and exceeding the needs and expectations of their customers.

The main elements of this learner's guide are:

- Introduction:
 - This includes a brief description of guide and guidelines to use it effectively
- Modules:
 - The modules form the sections in this learner's guide
- Learning Units:
 - Learning Units are the main sections within each module
- Learning outcomes:
 - Learning outcomes of each learning units are taken from the curriculum document
- Learning Elements:
 - This is the main content of learner's guide with detail of the knowledge and skills (practical activities, projects, assignments, practices etc.) The learner will be required to achieve learning outcomes stated in the curriculum
 - This section will include examples, photographs and illustrations relating to each learning outcome
- Summary of modules:
 - This section contains the summary of the modules that make up this learner's guide
- Frequently asked questions:
 - These have been added to provide further explanation and clarity on some of the difficult concepts and areas. This further helps learners for their your assessment.
- Multiple choice questions for self-test:
 - These are provided as an exercise at the end of your learner's guide to help the learners in preparing for their assessment.

SURGICAL INSTRUMENTS MANUFACTURING TECHNICIAN



© TVET SSP

Module-1
LEARNER GUIDE
National Vocational Certificate Level 3

Version 1 - May, 2019

Module 1: 072200883 Perform Forging

Objective of the module: The aim of this module is to develop the knowledge, skills and understanding needed to perform forging.

Duration: 28 hours **Theory:** 102 hours **Practical:** 28 hours

Learning Units	Learning Outcomes	Learning Elements	Materials Required
<p>LU1: Perform Sheet Cutting</p>	<p>The learner will be able to:</p> <p>Arrange suitable material and Measure the thickness of sheet as per product specification / drawing</p> <p>Set shearing parameters as per required strip sizes</p> <p>Adjust the Jig size for sheet cutting on shearing press table</p> <p>Cut down the large size sheet into strips according to the job</p>	<p>Understanding safety precaution and Personal Protective Equipment for sheet cutting operations</p> <p>Understanding system of measurements and conversions (imperial & Metric Systems)</p> <p>Knowledge and use of Measuring Instruments and marking tools (e.g. Steel Rule, Vernier Caliper, Thickness Gauge, scriber etc.)</p> <p>Identify metal sheets by grades and gauges used for making surgical instruments through sheet cutting operations.</p> <p>Understanding the basics of technical</p>	<p>Measuring tools (Steel Rule, Measuring Tape, Tri square, scribe, compass, Vernier Caliper, Micrometer, filler Gauge, Sheet Gauge etc.)</p> <p>Drafting tables and equipment</p> <p>Work holding devices and attachments (Jig and fixtures)</p> <p>Shearing press</p> <p>Hammers (assorted range)</p> <p>Spanners</p> <p>Clamping set</p> <p>Tool kit</p> <p>Consumable:</p> <p>Metal sheets</p> <p>First aid box with complete accessories</p> <p>Personal protective equipment (Helmets, Safety Goggles, Safety Gloves, Safety Shoe, Ear plug/ muff, Apron etc.)</p> <p>Drawing sheets</p>

Learning Units	Learning Outcomes	Learning Elements	Materials Required
	<p>specification using shearing press</p> <p>Measure strips to verify required specifications</p> <p>Mount cutting die on power press to cut strips for pre-forge shape (Raw shape)</p>	<p>drawings and symbols</p> <p>Basic understandings of jigs and fixture.</p> <p>Knowledge about shearing press, its parts, types and operations (Stroke, alignments of jigs and fixtures) Setting parameters of shearing press</p> <p>Method of die setting, and its alignments, tools used in die setting (e.g. Clamps, spacers, spanner etc), techniques to reduce/ control die setting time.</p> <p>Understanding of time management</p> <p>Understanding of contingency management</p> <p>Knowledge about basic maintenance of shearing press</p> <p>Knowledge of defects in sheet cutting parts / pieces and its corrective measures.</p> <p>Understanding process travelling card (PTC) and its applications. (storage of job,</p>	

Learning Units	Learning Outcomes	Learning Elements	Materials Required
		quality, quantity etc)	
LU2: Apply hammer stroke	The learner will be able to: Mount both parts of forging dies on drop forged hammer Align forging dies as per standard procedure Heat up the pre-forged work pieces in furnace to achieve required temperature Place preheated pieces in forging die and apply hammer stroke as per requirements Remove the forged pieces out of die safely and place in storage	Understanding safety precaution and Personal Protective Equipment for drop forging operations Understand parts, specification, strokes techniques and operating of drop forging hammer Method of die setting/ mounting, and its alignments, tools used in die setting (e.g. Clamping set, spanner etc), techniques to reduce/ control die setting time Knowledge of setting furnace temperature and follow the thermo couple/ temperature controller display reading Knowledge of standard operating procedure for forging Understanding about handling techniques	Work holding devices and attachments (Jig and fixtures) Drop Forging Hammer Gas Heating furnace Hammers (assorted range) Forging die Spanners Clamping set Tongs (For holding forged work piece) Tool kit Consumable: Metal strip First aid box with complete accessories Personal protective equipment (Helmets, Safety Goggles, Safety Gloves, Face Mask, Safety Shoe, Ear plug/muff, Apron etc.)

Learning Units	Learning Outcomes	Learning Elements	Materials Required
	<p>container/trolley/bin</p> <p>Inspect the size and shape of forged pieces after cooling down to verify required specifications</p>	<p>of forged work piece</p> <p>Understanding of time management</p> <p>Understanding of contingency management</p> <p>Knowledge about basic maintenance of drop forging hammer and furnace</p> <p>Knowledge of types of defects in forged parts / pieces and its corrective measures (Misaligned forged parts)</p>	
<p>LU3: Trim material</p> <p>extra</p>	<p>The learner will be able to:</p> <p>Mount trimming die on power press</p> <p>Set press parameters (Daylight, stroke etc.) as per job requirements</p> <p>Trim the extra material from forged pieces on</p>	<p>Understanding safety precaution and Personal Protective Equipment for trimming operations</p> <p>Purpose of trimming operation and construction of trimming die</p> <p>Method of trimming die setting, and its alignments, tools used in die setting (e.g. Clamps, spacers, spanner etc)</p>	<p>Work holding devices and attachments(Jig and fixtures)</p> <p>Power press</p> <p>Hammers (assorted range)</p> <p>Trimming dies for different product</p> <p>Dial Indicator with Magnet Stand</p> <p>Spanners</p> <p>Clamping set</p> <p>Tool kit</p> <p>Consumable:</p> <p>Forged pieces</p> <p>First aid box with complete accessories</p> <p>Personal protective equipment (Helmets, Safety Goggles, Safety Gloves, Safety Shoe,</p>

Learning Units	Learning Outcomes	Learning Elements	Materials Required
	<p>power press</p> <p>Check quality of trimmed forged work pieces</p> <p>Perform cold stamping if required and store in designated place</p> <p>Prepare report of completed work on prescribed format</p>	<p>Understands techniques to reduce/ control die setting time.</p> <p>Knowledge about power press, its parts, types and operations (Stroke, daylight, alignments of jigs and fixtures) Setting parameters of power press</p> <p>Understanding Quality requirements of trimmed jobs, defects and corrective measures</p> <p>Knowledge and requirements of cold stamping method</p> <p>Understanding of time management</p> <p>Understanding of contingency management</p> <p>Knowledge about basic maintenance of drop forging hammer and furnace</p>	<p>Apron etc.)</p> <p>Process travel card</p>

Examples and illustrations

Introduction

Unguarded moving parts of machines/equipment and the sudden or uncontrolled release of their power systems can result in serious injuries.

Personnel working with machines must be aware of the risks involved and follow safe work practices.

Causes of accidents while working with machinery

- Loose clothing, hair, jewelry being caught in moving parts.
- Materials ejected from the machine when it is operational.
- Inadvertent starting of the machine.
- Slipping and falling into an unguarded nip.
- Contact with sharp edges, e.g., cutting blade.
- Making adjustments while the machine is operational.
- Unauthorized operation of machines.
- Lack of preventive maintenance.

Hazards-Rotating machine parts give rise to nip points. Examples are

- Rotating gears
- Belt and its pulley
- Chain and sprocket
- Between grinding wheel and tool rest
- Between rotating and fixed parts-Rotating parts operating alone
- Shafts
- Couplings-Reciprocating and sliding motions

http://www.iitb.ac.in/safety/sites/default/files/Machine%20Safety_0_0.pdf

Perform sheet cutting method: For the setting of machine, follow the procedure given below

Adjust the blade gap according to plate thickness;

Adjust the profile modeling and clamping according to the width of the material to be cut;

Before starting the shearing operation, empty run the machine for 1-3 times. Start cutting after everything confirmed no problem;

After cutting, should be able to ensure the surface straightness and parallelism requirements of the cutting edge, and to minimize the distortion of the plate in order to obtain high-quality work pieces.

The blade of the machine is fixed on the tool holder and edge of the bed is used as other part for shearing.

The working table is equipped with a ball carrier so that the sheet is not scratched when sliding on it.

The rear stop is used for sheet metal positioning and the position is adjusted by the motor.

The hold-down cylinder is used to press the sheet to prevent the sheet from moving during sheering.

The guard is a safety device to prevent possible accidents.

VIDEOS:



How to Perform sheet cutting?

<https://www.youtube.com/watch?v=i3594weanfY>



Understand parts, specification, strokes techniques and operating of drop forging hammer

<https://www.youtube.com/watch?v=31q0zn-105k>



Understanding safety precaution and Personal Protective Equipment for trimming operations

<https://www.youtube.com/watch?v=i061VSFh1OI>



Understanding system of measurements and conversions (imperial & Metric Systems)

https://www.youtube.com/watch?v=sNn_qsgBuM0

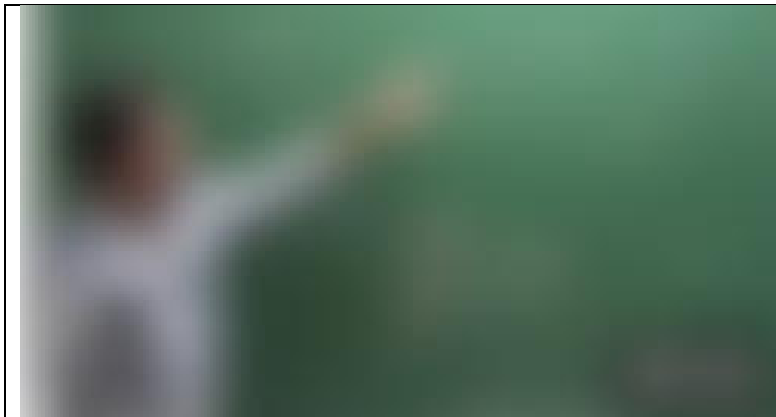

Knowledge and use of Measuring Instruments and marking tools (e.g. Steel Rule, Vernier Caliper, Thickness Gauge, scribe etc.)

<https://www.youtube.com/watch?v=DUI7OFwj4Uk>

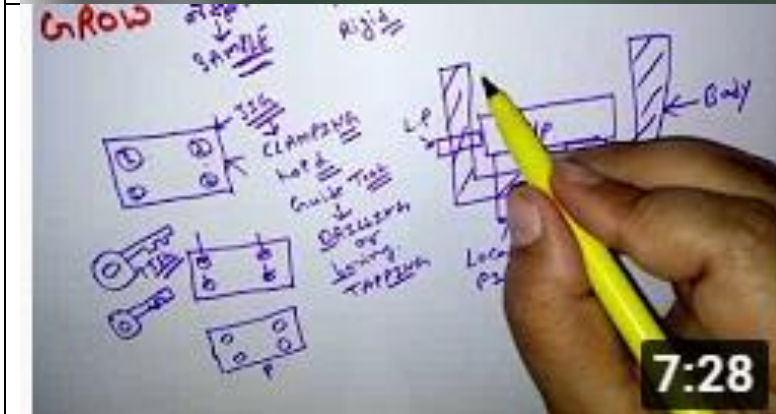

Basic understandings of jigs and fixture.

<https://www.youtube.com/watch?v=ETLJoxEMdZc>



Method of die setting, and its alignments, tools used in die setting (e.g. Clamps, spacers, spanner etc), techniques to reduce/ control die setting time.

<https://www.youtube.com/watch?v=lp7S9ZRNYeo>



Understanding Quality requirements of trimmed jobs, defects and corrective measures

<https://www.youtube.com/watch?v=Yc3AIPQ-9x0>



Knowledge and requirements of cold stamping method

<https://www.youtube.com/watch?v=5CuJjSk4U38>

<https://www.youtube.com/watch?v=clkqYA8LLSA>



How to perform the Time management?

<https://www.youtube.com/watch?v=KJLHIOldqA4&t=128s>

<https://www.youtube.com/watch?v=IdCnZMkOArY>







How to understand the contingency management?

<https://www.youtube.com/watch?v=8bTyDOY4oVs>





<https://www.youtube.com/watch?v=OxKX4oTdt9Q>

Emergency notices

Sign	Description
 A red square sign with a white fire extinguisher and flames.	Fire Extinguisher sign - displayed next to all fire extinguishers to easily identify the location of the nearest extinguisher.
 A red square sign with a white hand pointing to a call point and flames.	Fire Alarm Call Point sign - located at all fire alarms.
 A red square sign with a white fire hose reel and a cross symbol.	Fire Hose Reel sign – located at all fire hose points.
 A red square sign with a white fire blanket and flames, with the text 'Fire Blanket' written in white.	Fire Blanket sign - located at all fire blanked locations
 A red circle with a diagonal slash over a white lift icon.	In Case of Fire, Do Not Use the Lift sign - displayed at all lifts alongside the 'Use Stairs' sign to indicate safe escape route.

Sign	Description
	<p>Fire Door Keep Shut sign - displayed on each side of all fire doors to ensure safety.</p>
	<p>Fire Exit sign - displayed along all designated fire escape routes (with arrows) and above all emergency exits (without arrows).</p>
	<p>Fire Assembly Point - a pictogram or written sign displayed at the outside point of assembly where people must gather after evacuation.</p>
	<p>In Case of Fire, Use Stairs sign - an information sign displayed next to lifts and at the top of staircases so people know not to use the lift for safety reasons.</p>

Main types of portable extinguishers, their uses and colour coding

WATER For wood, cloth, coal, plastics, paper, textile, and other solid material fires.	POWDER For solid material, liquid, gas, and electrical fires.	FOAM For solid material and liquid fires.	CARBON DIOXIDE (CO₂) For liquid and electrical fires.	WET CHEMICAL For fires that involve cooking oils and fats.
				
NOT SUITABLE FOR all other types of fires.	NOT SUITABLE FOR chip or fat pan fires or metal fires (unless it is M28 or L2)	NOT SUITABLE FOR gas, metal, electrical, or chip and fat pan fires.	NOT SUITABLE FOR gas, metal, or chip and fat pan fires.	NOT SUITABLE FOR other types of fires (use a more appropriate extinguisher).

For more detailed information, please visit <https://www.highspeedtraining.co.uk/hub/fire-safety-signs/>

First aid equipment



Standard Kit Contents:	Small	Medium	Large
Guidance Leaflet	1	1	1
Medium Sterile Dressings	4	6	8
Large Sterile Dressing	1	2	2
Triangular Bandages	2	3	4
Safety Pins	6	12	24
Eye Pad Sterile Dressings	2	3	4
Blue Detectable Plasters	40	60	100
Sterile Cleansing Wipes	20	30	40
Adhesive Tape	1	1	1
Nitrile Disposable Gloves (Pairs)	6	9	12
Finger Sterile Dressings	2	3	4
Resuscitation Face Shield	1	1	2
Foil Blanket	1	2	3
Hydrogel Burn Dressing	1	2	2
Shears	1	1	1
Conforming Bandage	1	2	2
Green Moulded Case	1	1	1

For more detailed information, please visit

<https://www.eurekadiirect.co.uk/First-Aid-Kits-Cabinets/Catering-First-Aid-Kits/Catering-Kit-BS85991-Compliant-Standard-Case>

Accident and incident log



Accident and Incident Log



Date & Time	Who was involved	What happened	Outcome	A & I Form completed by	Who was responsible for taking to office & when	
					Print Name	
					Print Name	
					Sign	
					Date	
					Print Name	
					Sign	
					Date	
					Print Name	
					Sign	
					Date	
					Print Name	
					Sign	
					Date	

Accident & Incident log uploaded to web June 2014

For more detailed information, please visit <https://www.youtube.com/watch?v=inZczv3bLu4>

PTC (Process Traveler Card)

Knowledge about process travel card.

Company Name					Forms	
Effective Date	09.04.2018	Rev #	01	Rev. Date	09.04.2018	

PROCESS TRAVELER
PIT-17-01-01

INSTRUMENT _____ Sample /Cat. No. _____
 STEEL BATCH NO. _____ LOT NO. _____

Sr #	Mfg. Steps	Units started	Completed by	Date completed	Units accepted	Units reworked	Units rejected	Prod. Foreman by	QA Checked by
1.	Cutting								
2.	Forging								
3.	Milling								
4.	Assembling								
5.	Grinding								
6.	QA Inspection 4%								**
7.	H. Treatment								
8.	Hardness								
9.	Acid								
10.	Fitting								
11.	Spot Weld								
12.	Rough Polish								
13.	U. Clean								
14.	E. Polish								
15.	Setting/Adj								
16.	Sand Blast								
17.	Final Polish								
18.	Satin Finish								
19.	U. Clean								
20.	Passivation								
21.	Boil Test								
22.	Marking								
23.	Oiling								
24.	QA Inspection 4 %								**
25.	Packing								
26.	Label								

*Vendor Step ** Identifies QA Checks and all other Inspections are by Manufacturing

SURGICAL INSTRUMENTS MANUFACTURING TECHNICIAN



© TVET SSP

Module-2
LEARNER GUIDE
National Vocational Certificate Level 3

Version 1 - May, 2019

Module 2: 072200884 Perform Manual Machining

Objective of the module: The aim of this module to develop the knowledge, skills and understanding needed to Perform manual machining.

Duration: 130 hours **Theory:** 102 hours **Practical:** 28 hours

Learning Unit	Learning Outcomes	Learning Elements	Materials Required
<p>LU1: Perform turning operations</p>	<p>The learner will be able to: Arrange material for turning operations according to job requirement Prepare work-piece by required machining (sawing and filing etc.) and get it ready for clamping Arrange tools, measuring instruments and holding devices as per work instructions Clamp and align the work piece and tools on lathe machine Set lathe machine parameters (Spindle speed (rpm), feed etc.) according to the machining requirements</p>	<p>Understand safety precaution and Personal Protective Equipment and workplace safety</p> <p>Identify materials used in commonly produced surgical instruments (Mild steel, Teflon, aluminium, Stainless steel, Brass, etc)</p> <p>Identify commonly produced surgical instruments that require lathe machine operations</p> <p>Understand work specifications, and instructions for lathe machine</p> <p>Understand using files (Flat file, round file needle file etc), saws, its types and operating techniques.</p> <p>Knowledge of measurement systems</p> <p>Understand using measuring and marking tools</p>	<p>Lathe machine (with standard accessories)</p> <p>Power hacksaw machine</p> <p>Hand hacksaw</p> <p>Measuring and marking tools (Vernier Callipers, Micrometres, scribe, punch etc)</p> <p>Work holding devices and attachments of lathe machine (Face plate, Mandrill, Chuck, Drill Chuck, Lathe centres etc)</p> <p>Pedestal grinder with cutting angle support</p> <p>Hammers (assorted range)</p> <p>Radius gauge - concave & convex (assorted range)</p>

Learning Unit	Learning Outcomes	Learning Elements	Materials Required
	<p>Perform machining to achieve required dimensions and surface finish</p> <p>Use appropriate measuring tools & instruments to ensure the quality and measurements of work piece according to standards</p>	<p>(Vernier Callipers, Micrometres, Thread Gauge, Radius Gauge, scribe, punch, Dial Indicator with magnetic stand etc)</p> <p>Understanding lathe machine construction, sizes, types and operations (Turning, Facing, Drilling, Boring, Threading etc)</p> <p>Understanding about cutting tools materials and geometry (Turning, boring, knurling, threading tools etc)</p> <p>Knowledge about tool bit grinding as per tool geometry</p> <p>Knowledge about work holding devices and attachments (Face plate, Mandrill, Chucks etc)</p> <p>Understand safe clamping practices of tool and work piece</p> <p>Understand job and tool clamping methods for Lathe machines</p> <p>Understand Importance and usage of cutting</p>	<p>Threads gauge -inches / millimeters (assorted range)</p> <p>Bench vices</p> <p>Boring head</p> <p>Plug and snap gauges</p> <p>Dial indicator with magnet stand</p> <p>Maintenance kit</p> <p>Consumable:</p> <p>First aid box with complete accessories</p> <p>Personal protective equipment (Helmets, Safety Goggles, Safety Gloves, Safety Shoe, Face Mask, Apron etc.)</p> <p>Work piece material (Mild steel, Teflon, aluminium Stainless steel, Brass etc)</p> <p>Hacksaw blades</p> <p>Different grades of grinding wheel (for HSS tool bits and Tungsten carbide tip tool</p> <p>Different types of Files</p>

Learning Unit	Learning Outcomes	Learning Elements	Materials Required
		<p>lubricants</p> <p>Understand setting feed, depth of cut and spindle speed (RPM) according to the work-piece and tool materials</p> <p>Understanding of time management</p> <p>Understanding of contingency management</p> <p>Knowledge about basic maintenance of lathe machine</p> <p>Understand common defects in machined components and its corrective measures.</p>	<p>Tap set</p> <p>Drill set</p> <p>Range of lathe cutting tools (HSS Tool Bit, Tungsten Carbide tips tool etc.)</p> <p>Lubricant oil</p> <p>Coolant</p> <p>Cleaning Brushes</p> <p>Cleaning Clothes</p>
<p>LU2: Perform milling operations</p>	<p>The learner will be able to:</p> <p>Arrange material for milling operations according to job requirement</p> <p>Prepare work-piece for required machining (sawing and filing)</p>	<p>Understand safety precaution and Personal Protective Equipment and workplace safety</p> <p>Identify materials used in commonly produced surgical instruments (Mild steel, Teflon, aluminium, Stainless steel, Brass, etc)</p> <p>Knowledge about commonly produced surgical</p>	<p>Vertical and Horizontal milling machines (with standard accessories)</p> <p>Power hacksaw</p> <p>Shaper machine</p> <p>Tool and cutter grinder</p> <p>Surface grinder</p>

Learning Unit	Learning Outcomes	Learning Elements	Materials Required
	<p>etc.) and get it ready to clamp</p> <p>Arrange the cutters, measuring instruments and holding devices as per work instructions</p> <p>Clamp and align the work piece and tool on milling machine</p> <p>Set milling machine parameters (Spindle speed(rpm), feed, depth of cut etc.) according to the machining requirements</p> <p>Perform milling to achieve required dimensions and surface finish</p> <p>Use appropriate measuring tools & instruments to ensure the quality and measurements of work piece according to standards</p>	<p>instruments that require milling machine operations</p> <p>Understand work specifications, and instructions of milling machine</p> <p>Understand using files, saws, its types and operating techniques.</p> <p>Knowledge of measurement systems</p> <p>Understand using measuring and marking tools (Vernier Callipers, Micrometers, Height Gauge, Dial indicator with Magnetic stand, tri square, scribe, depth micrometer etc)</p> <p>Understanding milling machine construction, sizes, types and operations (Face milling, side milling, slotting, serration etc)</p> <p>Understanding about Milling Cutters, material and geometry (End mill cutter, T-slot cutter, Concave and convex cutters, saw cutter etc)</p> <p>Knowledge about work holding devices, attachments and fixtures (Clamping sets, Machine vices, tool</p>	<p>Drill machine</p> <p>Hand hacksaw</p> <p>Measuring and marking tools (Vernier Callipers, Micrometers, Height Gauge, Dial indicator with Magnetic stand, tri square, scribe, depth micrometer etc)</p> <p>work holding devices and attachments (Clamping sets, Machine vices, tool holders and collets set, spacer etc)</p> <p>Pedestal grinder with cutting angle support</p> <p>Hammers (assorted range)</p> <p>Bench vices</p> <p>Dividing head and rotary table</p> <p>Dial indicator with magnet stand</p> <p>Maintenance kit</p> <p>Consumable:</p> <p>First aid box with complete accessories</p> <p>Personal protective equipment (Helmets, Safety Goggles, Safety Gloves, Safety Shoe, Apron etc.)</p>

Learning Unit	Learning Outcomes	Learning Elements	Materials Required
		<p>holders and collets set, Rotary table, dividing head spacer etc)</p> <p>Understand safe clamping practices of tool and work piece</p> <p>Understand job and tool clamping methods for milling machines</p> <p>Understand Importance and usage of cutting lubricants</p> <p>Understand setting feed, depth of cut and spindle speed (RPM) according to the work-piece and cutter materials</p> <p>Understanding of time management</p> <p>Understanding of contingency management</p> <p>Knowledge about basic maintenance of milling machine</p> <p>Understand common defects in machined components and its corrective measures</p>	<p>Work piece material (Mild steel, Teflon, aluminium Stainless steel, Brass, etc)</p> <p>Hacksaw blades</p> <p>Files</p> <p>Range of milling cutters according to material (HSS Cutter, Carbide cutters etc.)and its operations (End mill cutter, T-slot cutter, Concave and convex cutters, saw cutter etc)</p> <p>Lubricant oil</p> <p>Coolant</p> <p>Cleaning Brushes</p> <p>Cleaning Clothes</p>

Videos



Understanding lathe machine construction, sizes, types and operations (Turning, Facing, Drilling, Boring, Threading etc)

How to perform lathe machine operation?

<https://www.youtube.com/watch?v=XXpOwsD0fWM>

<https://www.youtube.com/watch?v=SvIZHHDXCZs>

<https://www.youtube.com/watch?v=Za0t2Rfjewg>



Identify materials used in commonly produced surgical instruments (Mild steel, Teflon, aluminium, Stainless steel, Brass, etc)

How to check the material?

<https://www.youtube.com/watch?v=7Qjjsn848Z4>

Machining Skills for Prototype Development

How to perform Milling machine operation?

<https://www.youtube.com/watch?v=Za0t2Rfjewg>

<https://www.youtube.com/watch?v=SOOnPEwP9bCA>

MILLING OPERATIONS

- ❖ Plain or slab milling
- ❖ Face milling
- ❖ End milling
- ❖ Slot milling
- ❖ Angular milling
- ❖ Form milling
- ❖ Straddle milling
- ❖ Gang milling
- ❖ Slitting or saw milling

How many types of Milling machines?

https://www.youtube.com/watch?v=GSdgl_ERcpU

https://www.youtube.com/watch?v=TecC9_nwpUw

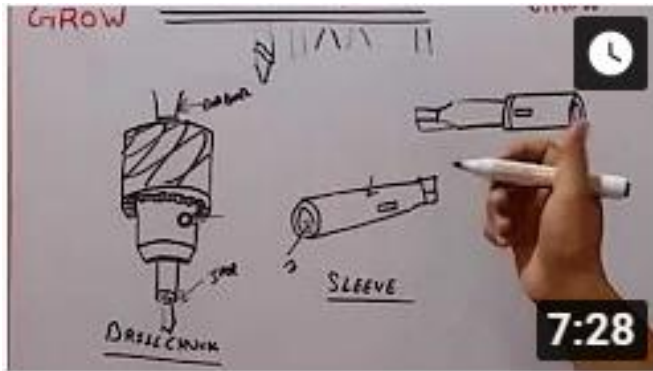

Knowledge about work holding devices and attachments (Face plate, Mandrill, Chucks etc)

<https://www.youtube.com/watch?v=RJu9JThUgpQ>
<https://www.youtube.com/watch?v=8b3ERCmAFks>



Understand safe clamping practices of tool and work piece

<https://www.youtube.com/watch?v=bbMbFvsRTJo>



Understand using measuring and marking tools (Vernier Callipers, Micrometers, Height Gauge, Dial indicator with Magnetic stand, tri square, scribe, depth micrometer etc)

<https://www.youtube.com/watch?v=VcOMLpjDa9c>



Understand using measuring and marking tools (Vernier Callipers, Micrometers, Height Gauge, Dial indicator with Magnetic stand, tri square, scriber, depth micrometer etc)

https://www.youtube.com/watch?v=d_xFRbM57pw



Understand using measuring and marking tools (Vernier Callipers, Micrometers, Height Gauge, Dial indicator with Magnetic stand, tri square, scriber, depth micrometer etc)

<https://www.youtube.com/watch?v=TrRcEq0NB9A>

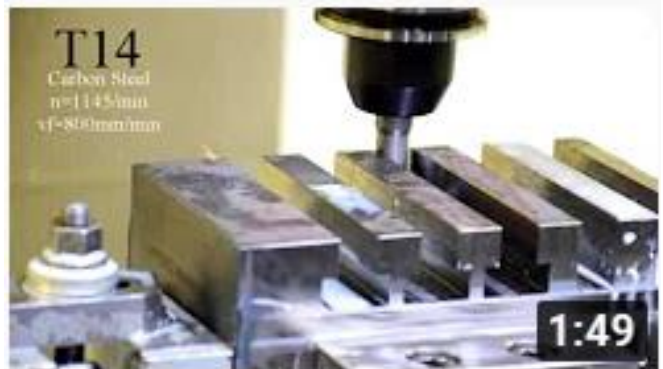

Understanding about Milling Cutters, material and geometry (End mill cutter, T-slot cutter, Concave and convex cutters, saw cutter etc)

<https://www.youtube.com/watch?v=achdNvz8RGQ>



Understanding about Milling Cutters, material and geometry (End mill cutter, T-slot cutter, Concave and convex cutters, saw cutter etc)

<https://www.youtube.com/watch?v=KT1eaDoQ8ww>

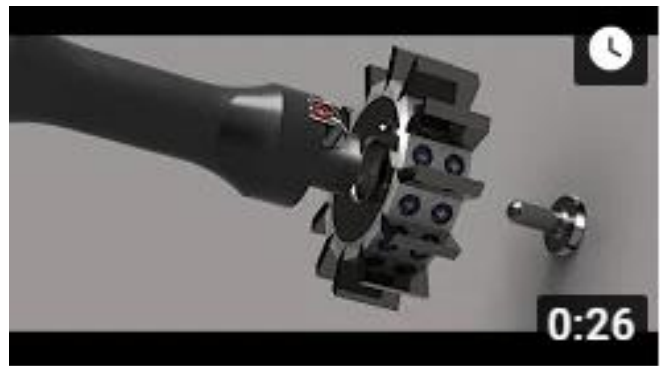

Understanding about Milling Cutters, material and geometry (End mill cutter, T-slot cutter, Concave and convex cutters, saw cutter etc)

<https://www.youtube.com/watch?v=DvWDq7PmLFk>



Knowledge about work holding devices, attachments and fixtures (Clamping sets, Machine vices, tool holders and collets set, Rotary table, dividing head spacer etc)

<https://www.youtube.com/watch?v=RzmqjxgVUAM>



Knowledge about work holding devices, attachments and fixtures (Clamping sets, Machine vices, tool holders and collets set, Rotary table, dividing head spacer etc)

https://www.youtube.com/watch?v=IDnihonia_E



Knowledge about work holding devices, attachments and fixtures (Clamping sets, Machine vices, tool holders and collets set, Rotary table, dividing head spacer etc)

<https://www.youtube.com/watch?v=4mhT1a28qO0>

Examples and illustrations

The operation which is performed by using special attachments are:

Turning:

It is the most common type of operation in all lathe machine operations. Turning is the operation of removing the excess material from the work piece to produce a cylindrical surface to the desired length.

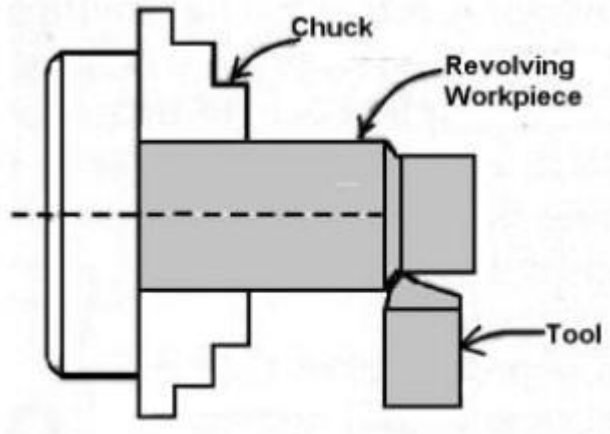

Turning Operation

:

Taper Turning:

- A "taper" is the uniform increase or decrease in the diameter of the work piece and measured along with its length.
- Taper turning means to produce a conical shape by a gradual reduction in diameter from a cylindrical work piece.

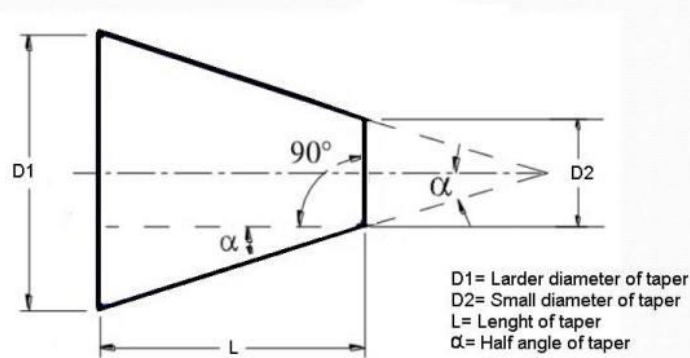

The amount of taper in the work piece is usually specified on the basis of the difference in diameter of the taper to its length. It is known as a cone and it is indicated by the letter K.

It has the formula $K = D-d / L$ to produce the taper on the work piece.

- D = Larger diameter of taper.
- d = Small diameter of taper.
- In the case of a lathe, the taper on a given work piece is obtained by tuning the job and feeding the tool at an angle to produce a gradual increase or decrease in the diameter of the work piece.
- The two important types of tapers are,
 - " More taper" here, the angle is very small and varies from 1.4 to 1.5°.
 - " Metric taper" is available in seven standard sizes with standard taper angles.
- Methods of taper turning,
 - Form tool method
 - Combined feeds method
 - Compound rest method or swiveling compound rest method
 - Tailstock set over method
 - Taper turning attachment method

Form tool method

Here the taper length obtain is equal to the width of the form tool. To obtain the required size of the taper the form tool is fed slowly straight into the work piece by operating the cross-slide perpendicular to the lathe axis.

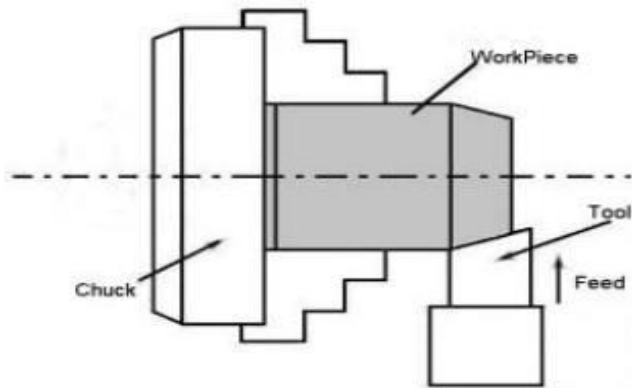

Taper Turning Using Form Tools.

This is the simplest method of taper turning. It is limited to obtain small taper length such as chamfering the side of the work piece. The method is done at a faster rate.

2. Combined feeds method

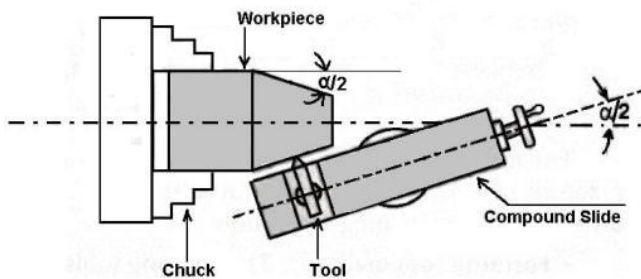

Taper Turning

The combined feed is made with the movement of a tool in longitudinal and lateral direction simultaneously while moving the work piece.

- Taper:
$$\tan \alpha = \frac{D_1 - D_2}{2L}$$

The taper, which we are going to obtain, is equal to the resultant to the magnitude of the longitudinal and lateral feeds. Changing the feeds rates in both directions can change the direction and the taper angle.

3. Compound rest swivel method

Here the work piece rotates and the tool is fed at an angle by swivelled compound rest. The base of the compound rest is graduated in degrees.

The taper angle is the angle at which the compound rest to be rotated is calculated by using the formula $\tan \alpha = D-d / 2l$, where, D= bigger diameter, d = smaller diameter, l = length of the work piece.

Compound rest can be swivelled to the required angle α . Once the compound rest is set to a particular angle then the tool is moved by compound rest and wheel.

4. Taper turning attachment method

- This method is similar to the compound rest method.
- Here the job or work piece rotates and the tool is fed at the taper angle α .
- In this, arrangement, which has guide block graduated in degrees, with the help of this the block can be required taper angle to the lathe axis.
- The taper angle is calculated similarly to the compound rest method using the formula: $\tan \alpha = D-d / 2l$.

Advantages of taper turning attachment:

- Internal tapers can be obtained accurately.
- large size tapers can be easily obtained.
- Once the attachment is set the taper turning operation can do at a faster rate.
- By setting the taper angle to 'zero' we can carry out plain turning.

Disadvantages of taper turning attachment:

- It requires additional mounting facilities.
- Fitting and removing attachment consume more time.
- The attachment has to take large forces.

Tailstock set over method:

Here the work piece on the job is tilted at the required taper angle. The tool is fed parallel to the axis.

The tilting of the work piece or the job to the required taper angle is achieved by the movement of the tailstock with the help of tailstock set over the screw. This method is useful for small tapers.

Facing:

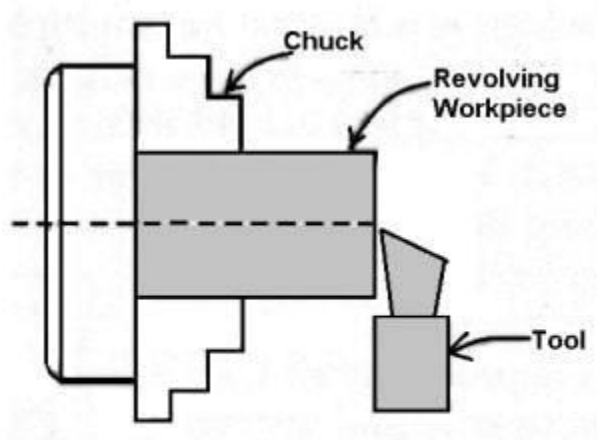

Facing Operation

It is an operation of reducing the length of the work piece by feeding the perpendicular to the lathe axis. This operation of reducing a flat surface on the end of the work piece. For this operation, regular turning tool or facing tool may use. The cutting edge of the tool should set to the same height as the centre of the work piece.

Facing consist of 2 operations

- Roughing: Here the depth of cut is 1.3mm
- Finishing: Here the depth of cut is 0.2-0.1mm.

Chamfering operation:

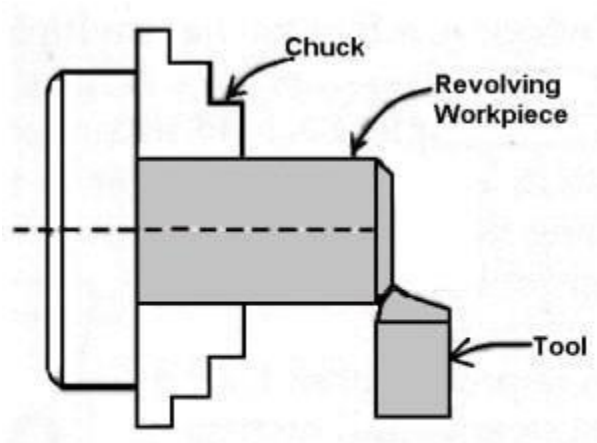

Chamfering

It is the operation of getting a bevelled surface at the edge of a cylindrical workpiece. This operation is done in case of bolt ends and shaft ends. Chamfering helps to avoid damage to the sharp edges and protect the operation getting hurt during other operations. Chamfering on bolt helps to screw the nut easily.

Knurling operation:

It is an operation of obtaining a diamond shape on the workpiece for the gripping purpose. This is done to provide a better gripping surface when operated by hands. It is done using a knurling tool. The tool consists of a set of hardened steel roller, and it is held rigidly on the tool post.

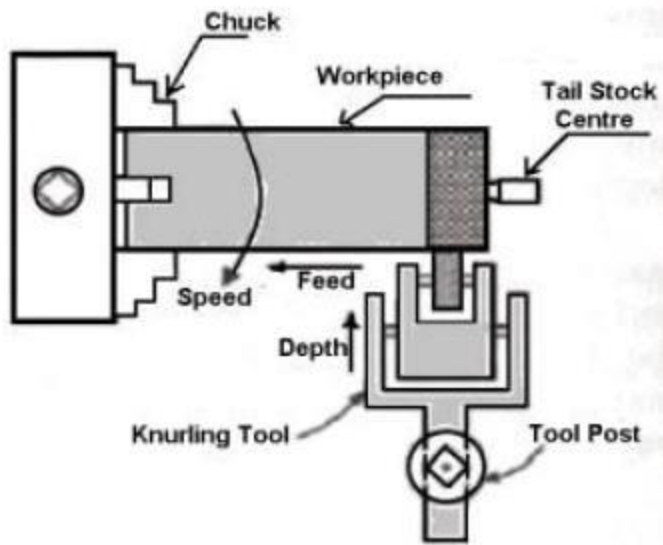

Knurling

Knurling is done at the lowest speed available on a lathe. It is done on the handles and also in case of ends of gauges. The feed varies from 1 to 2 mm per revolution. Two or three cuts may be necessary to give the full impression.

Thread cutting:

It is the important operation in the lathe to obtain the continuous "helical grooves" or "threads".

When the threads or helical grooves are formed on the out surface of the work piece is called external thread cutting. When the threads or helical grooves are formed on the inner surface of the work piece is called internal thread cutting. The work piece is rotating between the two centres i.e., live centre and dead centre is the lathe.

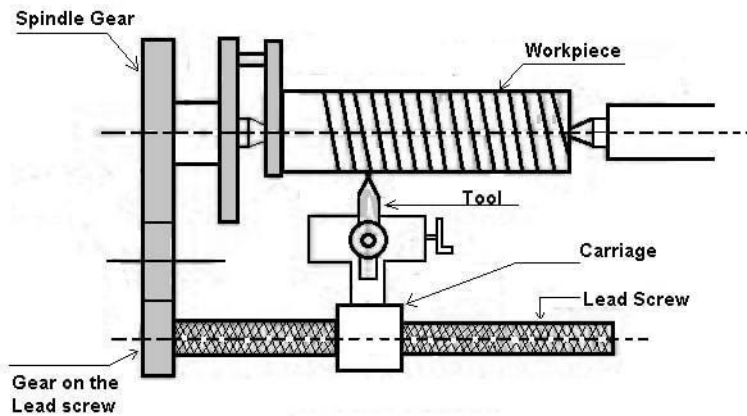

Thread Cutting

Here the tool is moved longitudinally to obtain the required type of the thread. When the tool is moved from right to the left we get the left-hand thread. Similarly, when the tool is moved from left to the right, we get the right-hand thread.

Here the motion of the carriage is provided by the lead screw. A pair of change gears drives the lead screw and by rotating the handle the depth of cut can be controlled.

Boring:

Boring is the operation of enlarging the hole which is already drilled, punched or forged. It cannot produce a hole. Boring is similar to the external turning operation and can be performed in a lathe. In this operation, the work piece is revolved in a chuck or a faceplate and the tools which are fitted to the tool post is fed into the work.

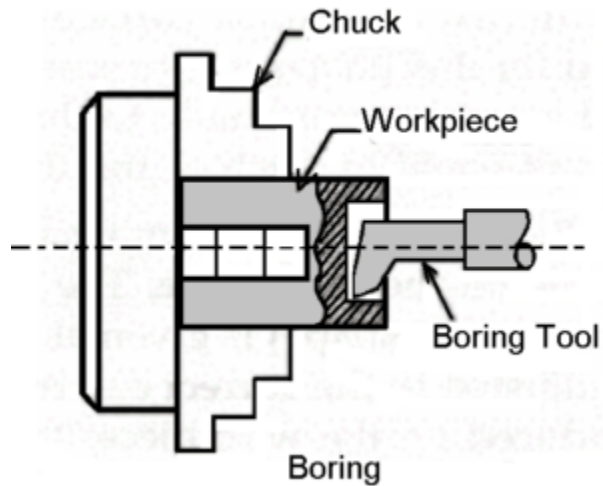

It consists of a boring bar having a single-point cutting tool which enlarges the hole. It also corrects out of roundness of a hole. This method adopted for boring small-sized works only. The speed of this process is slow.

Taper Boring:

The principle of turning a tapered hole is similar to the external taper turning operation and is completed by rotating the work on a chuck or a faceplate. The feeding tool is at an angle to the axis of rotation of the workpiece.

A boring tool is mounted on the tool post and by swivelling the compound slide to the desired angle, a short taper hole is machined by hand feeding.

Undercutting:

Undercutting is similar to grooving operation when performed inside a hole. It is the process of boring a groove or a large hole at a fixed distance from the end of a hole.

This is similar to the boring operation, except that a square nose parting is used. Undercutting is done at the end of an internal thread or a counter bore to provide clearance for the tool or any part.

Milling Machine

The milling process removes material by performing many separate, small cuts. This is accomplished by using a cutter with many teeth, spinning the cutter at high speed, or advancing the material through the cutter slowly; most often it is some combination of these three approaches.

Milling Machine Operation

The different milling machine operation is:

Face Milling

This operation makes flat surfaces at the face of work piece. This machining operation is done on the surfaces which are perpendicular to the axis of the cutter. The operation is performed by the face milling cutter mounted on stub arbour of the machine.

Side Milling

It is the machining process which produces flat vertical surface at the sides of a work piece. This operation is performed by using side milling cutter.

Plain Milling

It is a Process of milling flat surfaces keeping the axis of the cutter parallel to the surface being milled. It is also called surface milling or slab milling. A plain milling cutter is used for the plain milling.

Straddle Milling

it is a process in which two side milling cutters are used to machined two opposite sides of a work piece simultaneously. The straddle milling operation is shown in the figure given below.

Angular Milling

It is a process of milling flat surfaces which are neither Parallel nor perpendicular to the axis of the milling cutter. It is also called as angle milling. A single angle milling cutter is used to perform this operation.

Gang Milling

It is the machining process in which two or more milling cutters are used together to perform different milling operation simultaneously. In gang milling the cutters are mounted on the Arbor.

Form Milling

It is the process of machining special contour (outline) composed of curves, straight lines, or entirely of curves, at a single cut. Formed milling cutters shaped to the contour to be cut are used to perform this operation. This operation is accomplished by using convex, concave and corner rounding milling cutters.

Profile Milling:

This milling operation is used to cut a profile on the work piece.

End Milling

It is the process of producing flat surfaces which may be horizontal, vertical and at any angle taking worktable as a reference. End milling cutters are used to accomplish this operation.

Saw Milling

- It is machining process which is used to produce narrow grooves or slots on the work piece.
- It is also used for the parting off the work piece into two equal or unequal parts.
- This milling operation is performed by using saw milling cutter.
- The width of this cutter is very less as compared with the width of the work piece.

Milling Key Ways, Grooves and Slots

This milling operation is used to produce key ways, grooves and slots on the work piece.

Gear Milling

It is the milling process which is used to cut gears on the work piece. This operation is done by using formed milling cutters called involute gear cutters.

Helical Milling

This milling operation is done to produce objects having helical design such as helical gears, twisted drills etc. it is done on the periphery of the cylindrical work piece.

Cam Milling

It is a machining process which is used to make cams. The cams are used to open and close of the valves in the internal combustion engines.

Thread Milling

It is the process of milling used to cut threads on the cylindrical work piece.

This is all about what is milling machine-operation parts and types. If you find any improvement in the article please tell us through your valuable comments. And if you find this article informative & useful, please don't forget to share.

Filing

A **file** is a tool used to remove fine amounts of material from a workpiece. It is common in metalworking, and other similar trade and hobby tasks. Most are hand tools, made of a case-hardened steel bar of rectangular, square, triangular, A file is a tool used to remove fine amounts of material from a workpiece. It is common in woodworking, metalworking, and other similar trade and hobby tasks. Most are hand tools, made of a case-hardened steel bar of rectangular, square, triangular, or round cross-section, with one or more surfaces cut with sharp, generally parallel teeth. A narrow, pointed tang is common at one end, to which a handle may be fitted.

A rasp is a form of file with distinct, individually cut teeth used for coarsely removing large amounts of material.

Files have also been developed with abrasive surfaces, such as natural or synthetic diamond grains or silicon carbide, allowing removal of material that would dull or resist metal, such as ceramic.

Types

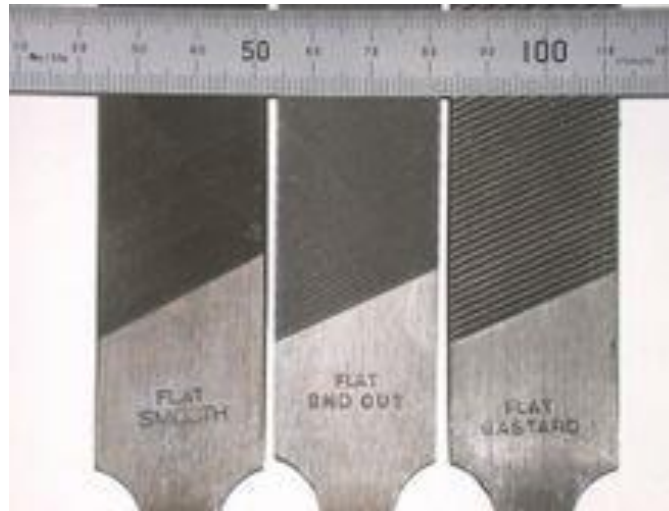

Relative tooth sizes for smooth, 2nd cut and bastard files

Files come in a wide variety of materials, sizes, shapes, cuts, and tooth configurations. The cross-section of a file can be flat, round, half-round, triangular, square, knife edge or of a more specialized shape. Steel files are made from high carbon steel (1.0 to 1.25% carbon) and may be through hardened or case hardened.

There is no unitary international standard for file nomenclature; however, there are many generally accepted names for certain kinds of files. A file is "blunt" if its sides and width are both parallel throughout its length. It is "tapered" if there is a reduction in its dimensions from its heel toward its point. A file may taper in width, in thickness, or both. A "tang" is a protrusion at the heel, tapered, parallel sided, or conical, for gripping, inserting in a handle, or mounting in a chuck.

The cut of the file refers to how fine its teeth are. They are defined as (from roughest to smoothest): rough, middle, bastard, second cut, smooth, and dead smooth. A single-cut file has one set of parallel teeth while a cross-cut or double-cut file has a second set of cuts forming diamond shaped cutting surfaces.^[1] In Swiss-pattern files the teeth are cut at a shallower angle, and are graded by number, with a number 1 file being coarser than a number 2, etc. Most files have teeth on all faces, but some specialty flat files have teeth on only one face or one edge, so that the user can come right up to another edge without damaging the finish on it.

Some of the common shapes and their uses:

Name	
Flat file	Similar to a mill file, but may be double-cut
Hand file	Parallel in width and tapered in thickness, used for general work
Square file	Gradually tapered and cut on all four sides. Used for a wide variety of tasks
Three square/Triangular file	Triangular in cross-section, which may taper gradually, often to a point on smaller files. The sides may be equal in cross-section, or have two long and one short surface
Rat tail	Round in cross-section and gradually tapered over their length. They are used for enlarging round holes or cutting scalloped edges
Round	Round in cross section and equal diameter over their length (not tapered). They are used for smoothing inside holes and circular grooves, and for sharpening certain kinds of saw.
Half round file	Has one flat and one convex surface, and either tapering slightly or maintaining an even thickness, width, or both over their length
Combination file	Tangles, flat sided or half-round, with two to four cutting surfaces, typically including a combination of single cut, double cut, or rasp

Diamond files



A selection of diamond impregnated files

Instead of having teeth cut into the file's working surface, diamond files have small particles of industrial diamond embedded in their surface (or into a softer material that is bonded to the underlying surface of the file). The use of diamonds in this manner allows the file to be used effectively against extremely hard materials, such as stone, glass or very hard metals such as hardened steel or carbide against which a standard steel file is ineffective. Diamond files are also the only type that may be used with a back-and-forth motion without damaging the file. These may also be called diamond laps, as the "teeth" are not regular projections, as in a file, but particles, usually shaped and located randomly and held in place by a softer (any other) material.

Needle files

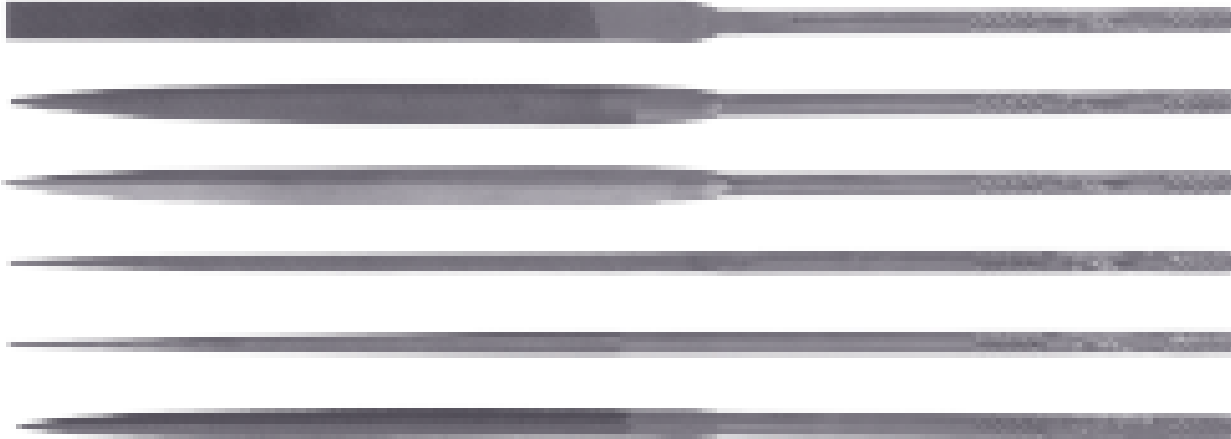

A needle file set depicting various shapes, from top to bottom: pillar, half round, barrette, square, round, triangular.

The image to the left shows a selection of needle files in an assortment of cross-sectional shapes.

Needle files are small files that are used in applications where the surface finish takes priority over metal removal rates but they are most suited for smaller work pieces. They are often sold in sets, including different shapes.

Machine Files



A selection of machine files

Files are produced specifically for use in a filing machine, which is similar in appearance to a scroll saw with a vertically reciprocating file mounted in the middle of a table. A workpiece is manipulated around the file's face as the shape requires.

A cone point (as pictured in the top and bottom files at left) allows a file to centre itself in its mount. Files with flat mounting surfaces must be secured with set screws.

Filing machines are rarely seen in modern production environments, but may be found in older toolrooms or die making shops as an aid in the manufacture of specialist tooling.

SURGICAL INSTRUMENTS MANUFACTURING TECHNICIAN



© TVET SSP

Module-3

LEARNER GUIDE

National Vocational Certificate Level 3

Version 1 - May, 2019

Module 3: 072200884 Develop Sheet Metal Surgical Instruments

Objective of the module: The aim of this module to develop the knowledge, skills and understanding needed to Develop Sheet Metal Surgical Instruments.

Duration: 130 hours **Theory:** 102 hours **Practical:** 28 hours

Learning Unit	Learning Outcomes	Learning Elements	Materials Required
<p>LU1: Perform blanking</p>	<p>The learner will be able to:</p> <p>Arrange material and tools required for blanking operation as per work instructions</p> <p>Set parameters to perform shearing on shearing press as per required strip sizes</p> <p>Mount blanking die on power press</p> <p>Adjust machine daylight and stroke according to sheet thickness</p>	<p>Understanding personal protective equipment and workplace safety for sheet metal works</p> <p>Knowledge and use of Measuring Instruments and (e.g. Steel Rule, Vernier Caliper, Micrometer, Thickness Gauge, etc.)</p> <p>Identify sheet metal materials and their grades and gauges (e.g. Stainless Steel etc)</p> <p>Identification of surgical instruments made of sheet metal (Hollow wear instruments etc)</p> <p>Understand work specifications, and instructions of blanking operation.</p>	<p>Measuring (e.g. Steel Rule, Vernier Caliper, Micrometer, Thickness Gauge, etc.)</p> <p>Clamping Set</p> <p>Tool kit with box</p> <p>Hand Hammers (assorted range)</p> <p>Power press</p> <p>Shearing Press</p> <p>Blanking dies</p> <p>Consumable:</p> <p>First aid box with complete accessories</p> <p>Personal protective equipment (Helmets, Safety Goggles, Safety Gloves, Safety Shoe, Apron, Ear Plug/Muff etc.)</p> <p>Metal Sheets material (Stainless Steel</p>

Learning Unit	Learning Outcomes	Learning Elements	Materials Required
	<p>Perform blanking on sheets</p> <p>Offload and store sheet scrap and blanks safely at designated places</p>	<p>Knowledge about shearing and power press for blanking, its parts, types and operations (Stroke, day light, alignments of jigs and fixtures)</p> <p>Knowledge about shearing and power press for blanking, its parts, types and operations (Stroke, day light, alignments of jigs and fixtures)</p> <p>Setting parameters of shearing and power press</p> <p>Understand methods and techniques of mounting and setting of blanking dies.</p> <p>Knowledge of blanking dies, punches and their components</p> <p>Understand quality of component produced using sheet metal</p> <p>Handling and transportation of punched jobs</p> <p>Understanding PTC (process travelling card) and its applications (Storage of job.</p>	

Learning Unit	Learning Outcomes	Learning Elements	Materials Required
		<p>quality, quantity etc)</p> <p>Understand the defects of sheet metal manufacturing and its corrective measures</p>	
<p>LU2: Perform punching</p>	<p>The learner will be able to:</p> <p>Arrange material and tools required for punching operation as per work instructions</p> <p>Mount and set punching die on press as per work specifications and procedures</p> <p>Adjust machine daylight and stroke according to sheet thickness</p> <p>Perform punching on blanks</p> <p>Offload and store work</p>	<p>Understand personal protective equipment and workplace safety for sheet metal punching</p> <p>Understand methods and techniques of mounting and setting of punching dies.</p> <p>Knowledge about power/ punching press for punching, its parts, types and operations (Stroke, day light, alignments)</p> <p>Setting parameters of power press</p> <p>Knowledge of dies, punches and their components</p> <p>Understand work specifications, and instructions.</p> <p>Understand quality of component produced</p>	<p>Hand Hammers (assorted range)</p> <p>Power/ punching press</p> <p>Punching dies</p> <p>Tool kit with box</p> <p>Clamping Set</p> <p>Consumable:</p> <p>First aid box with complete accessories</p> <p>Personal protective equipment (Helmets, Safety Goggles, Safety Gloves, Safety Shoe, Apron, Ear Plug/Muff etc.)</p> <p>Blanked work pieces for punching</p> <p>Process travel card</p>

Learning Unit	Learning Outcomes	Learning Elements	Materials Required
	pieces safely at designated place	using sheet metal Handling and transportation of punched jobs Understanding PTC (process travelling card) and its applications (Storage of job, quality, quantity etc) Understand the defects of sheet metal manufacturing and its corrective measures	
LU3: Perform bending	The learner will be able to: Arrange material and tools required for bending operation as per work instructions Adjust and set bending die on press as per work specifications and procedures. Adjust power / hydraulic press daylight and stroke according to sheet	Understand personal protective equipment and workplace safety for sheet metal bending Understand methods and techniques of mounting and setting of bending dies. Knowledge about power/ Hydraulic press for bending, its parts, types and operations (Stroke, day light, alignments) Setting parameters of power press Knowledge of bending dies, punches and their components	Hand Hammers (assorted range) Power/ Hydraulic press Bending dies Tool kit with box Consumable: First aid box with complete accessories Personal protective equipment (Helmets, Safety Goggles, Safety Gloves, Safety Shoe, Apron, Ear Plug/Muff etc.) Blanked/ punched work piece Process travel card

Learning Unit	Learning Outcomes	Learning Elements	Materials Required
	<p>thickness</p> <p>Start the required operations as per drawing and job specifications</p> <p>Offload and store work pieces safely at designated place</p>	<p>Understand work specifications, and instructions for bending operation.</p> <p>Understand quality of component produced using bended work pieces</p> <p>Handling and transportation of bended jobs</p> <p>Understanding PTC (process travelling card) and its applications (Storage of job, quality, quantity etc)</p> <p>Understand the defects of bended work pieces manufacturing and its corrective measures</p>	

<p>LU4: Apply deep draw process</p>	<p>The learner will be able to: Arrange material and tools required for deep draw operation as per work instructions Mount and set deep draw dies on hydraulic press as per work specifications and procedures. Punch marks using manual punches on the product wherever applicable Operate deep draw process on hydraulic press Offload and store work pieces safely at designated place</p>	<p>Understand personal protective equipment and workplace safety for sheet metal bending Understand methods and techniques of mounting and setting of deep draw dies. Knowledge about Hydraulic press for deep drawing, its parts, types and operations (Stroke, day light, alignments) Setting parameters of hydraulic press Knowledge of deep draw dies, punches and their components Understand work specifications, and instructions for deep draw process. Understand quality of component produced using deep drawing Handling and transportation of deep drawing jobs Understanding PTC (process travelling card) and its applications (Storage of job, quality, quantity etc) Understand the defects of deep drawing work pieces manufacturing and its corrective measures (Tearing, wrinkling etc)</p>	<p>Dial indicator with magnet stand Hammers (assorted range) Hydraulic press Deep draw dies Tool kit with box</p> <p>Consumable:</p> <p>First aid box with complete accessories Personal protective equipment (Helmets, Safety Goggles, Safety Gloves, Safety Shoe, Apron, Ear Plug/Muff etc.) Blanked/ punched work piece Process travel card</p>
<p>LU5: Perform spinning</p>	<p>The trainee will be able to: Arrange material and tools required for</p>	<p>The trainee will be able to: Arrange material and tools required for spinning operation as per</p>	<p>Spinning Lathe machine (with standard accessories) Dial indicator with</p>

	<p>spinning operation as per work instructions</p> <p>Clamp the work piece and tool on spinning lathe machine as per process requirement</p> <p>Apply force gradually to the spinning object to achieve required shape and size</p> <p>Use appropriate tools and gauges to ensure the quality of the product</p> <p>Offload and store work pieces safely at designated place</p> <p>Prepare report of completed work</p>	<p>work instructions</p> <p>Clamp the work piece and tool on spinning lathe machine as per process requirement</p> <p>Apply force gradually to the spinning object to achieve required shape and size</p> <p>Use appropriate tools and gauges to ensure the quality of the product</p> <p>Offload and store work pieces safely at designated place</p> <p>Prepare report of completed work</p>	<p>magnet stand</p> <p>Measuring instruments (e.g. Steel Rule, Vernier Caliper, Thickness Gauge, go and not go gauges etc.)</p> <p>Different range of spinning lathe tools</p> <p>Hammers (assorted range)</p> <p>Radius gauge - concave & convex (assorted range)</p> <p>Tool kit with box</p> <p>Consumable:</p> <p>First aid box with complete accessories</p> <p>Personal protective equipment (Helmets, Safety Goggles, Safety Gloves, Safety Shoe, Apron, Ear Plug/Muff etc.)</p> <p>Blanked/ punched work piece</p> <p>Process travel card</p>
--	--	--	--



How to perform Blanking?

<https://www.youtube.com/watch?v=7QrdmK2NTiU>
https://www.youtube.com/watch?v=PfoD-kyX_dw



How to perform punching?

<https://www.youtube.com/watch?v=Dmj42zD8yEs>
<https://www.youtube.com/watch?v=QWTzOg-Dk1Q>



How to perform Banding?

<https://www.youtube.com/watch?v=Nv4Gf1aj7SQ>



How to perform deep draw process?

<https://www.youtube.com/watch?v=wCiKdHMDbEo>

https://www.youtube.com/watch?v=VMu7_W0QE3Y



How to perform spinning?

<https://www.youtube.com/watch?v=43N44ICyuEU>

Example and illustration

Press Shut Height (Day light)

Shut height is defined as the distance from the bottom face of the ram (slide) to the top of the press bed, with the ram positioned at the very bottom of its stroke and ram adjustment set to the full-up position.

The press shut height can be found on a specification plate attached to the press frame and in the presses' technical manuals. Shut height may be expressed in inches, metric units or both. The press shut height listed on the specification plate is its maximum height. The ram has an adjustment screw that can be turned manually or by an electric motor to adjust the ram position downward to reduce the press shut height. The maximum amount of adjustment is determined by the adjustment-screw length. The maximum adjustment also is listed on the press-specification plate.

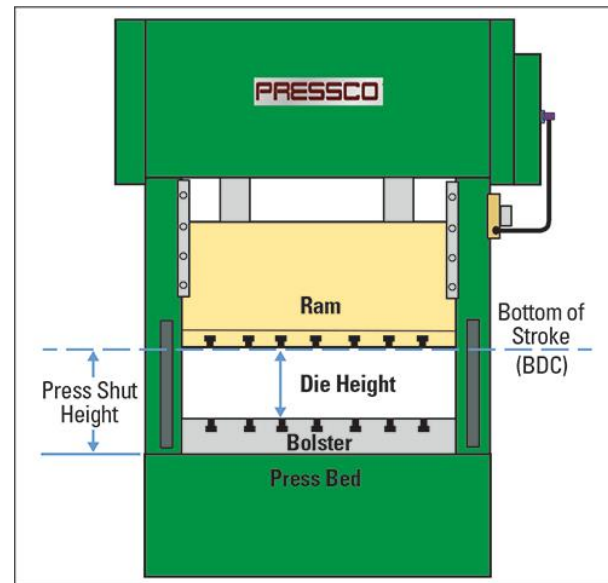

[Fig. 1] Die height and shut height in a press machine

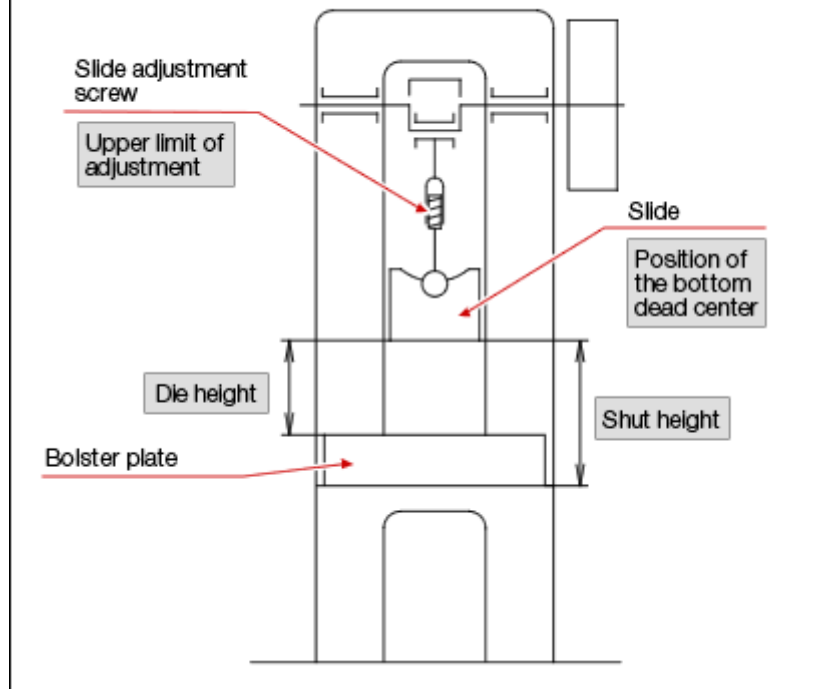

Deep Drawing Process

Method

The deep draw forming process begins with metal blanks. Typically, single blanks are used in order to facilitate the creation of parts or products with deeper shapes. Sometimes, these metal blanks will be placed on a reel to enable the metal to form efficiently. At each step in the deep drawing process, the metal blank is shaped through pressure applied by a metal die.

Though deep drawing is similar to metal stamping, the terms are not interchangeable. Stamping does not leave a single machine until the metal has completely formed. In general, deep drawing is used to fabricate parts and products that are deeper than metal stamping can accommodate.

The formability limitations of conventional deep drawing are a barrier for some industrial uses. Radial drawing stress and tangential compressive stress are a common concern that can result in wrinkling, fracturing or cracking in some applications. Numerous unconventional deep drawing techniques have recently been implemented that have helped increase the industrial uses of deep drawing. These processes include hydro forming, hydro-mechanical deep drawing, aqua drawing, hydraulic deep drawing, the Guerin process and the Mar form process.

Virtually all manufacturing industries have the potential to benefit from deep drawing manufacturing processes. The technique is perhaps most useful for manufacturing small component parts such as electronics relays, solenoids, and assembly housings. Products of all shapes and sizes, however, can be economically created through the process.

Perform spinning

Method

The metal spinning technique can apply to produce a wide variety of hollow parts of widely differing shapes, all without compromising the significant benefits of metal forming.

Metal spinning is a method of forming rotationally symmetrical sheet metal parts. In spinning, the sheet metal discs are formed into rotationally symmetrical hollow shapes. The blank is clamped between the shaped spinning mandrel and the tailstock of the spinning machine and rotated by the main drive. The metal disc and the mandrel rotate together and the spinning roller makes contact with the outer face of the workpiece. If a product is being spun by one of our skilled hand spinners, the same process is used but the operative applies the metal spinning roller by hand.

This metal spinning technique can be applied to produce a wide variety of hollow parts of widely differing shapes, all without compromising the significant benefits of metal forming. Often other processes can be incorporated into the same cycle. Any tooling that is required is not necessarily dictated by the shape of the component.

Meaning of Spinning:

Spinning is a sheet metal forming process in which a metal blank is pressed over a rotating chuck or form mandrel with the help of a pressing tool to obtain axisymmetric hollow shell.

The sheet metal parts that have circular cross-section can be made by this process. Generally, the shapes produced by spinning can also be manufactured by drawing, compressing or flanging.

However, spinning is usually used for forming large parts that require very large drawing process or when various shapes are needed but only a small number of each shape is required.

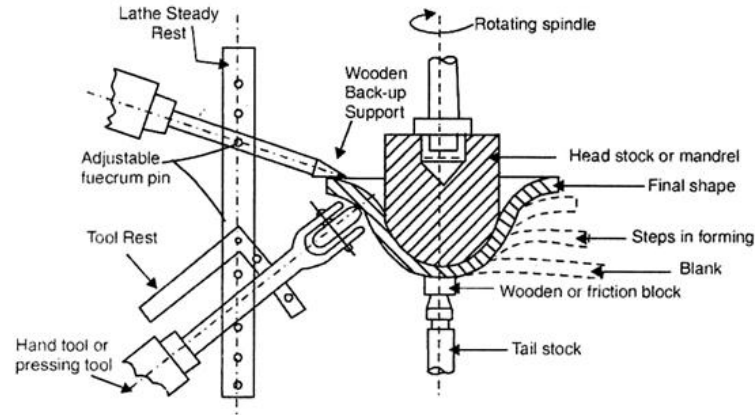

Fig. 8.1. A Schematic of the spinning operation.

Process of Spinning:

A Schematic of the spinning operation. The set-up essentially consists of a spinning machine similar to a centre lathe.

The various operation steps are:

- (i) The circular blank is properly centred and pushed by the tail stock against the front of the rotating chuck, usually made of wood. A wooden block is used from the tail-stock to support the blank.
- (ii) The chuck is rotated by the head-stock of a spinning lathe machine. The spinning speed depends on the blank material, thickness and complexity of the part required. It varies from a very slow to a high speed of about 3500 r.p.m.
- (iii) A hard wood or roller type metallic pressing tool is pushed by the operator onto the external surface of the blank.
- (iv) Then the tool is moved gradually on the blank so that it conforms to the shape of the form block or mandrel.
- (v) The blank slips under the pressing tool, which causes localized deformation. This deformation of the metal proceeds by a mixture of bending and stretching.
- (vi) To avoid wrinkles, a back-up support is applied to the opposite side of the pressing tool.
- (vii) Finally, the blank takes the exact shape of the form mandrel.

A modified version of this method involves replacing the operator by a NC (Numerical Controlled) tool. Better surface quality and more uniform thickness are the advantages of this NC spinning over conventional spinning technique.

Advantages of Spinning:

The spinning process usually used for forming large parts and when various shapes are needed but only a small number of each shape is required.

The spinning process is not suitable for large-scale production, as it consumes more time.

SURGICAL INSTRUMENTS MANUFACTURING TECHNICIAN



© TVET SSP

Module-4
LEARNER GUIDE
National Vocational Certificate Level 3

Version 1 - May, 2019

Module 4: 072200885 Apply Heat Treatment

Objective of the module: The aim of this module to develop the knowledge, skills and understanding needed to services apply heat treatment

Duration: 150 hours **Theory:** 120 hours **Practical:** 30 hours

Learning Unit	Learning Outcomes	Learning Elements	Materials Required
<p>LU1: Prepare workstation for heat treatment</p>	<p>The learner will be able to: Identify heat treatment processes required for the instrument using work instructions / specification sheets Arrange material, tools and gauges for the identified heat treatment processes Check quality of work pieces before heat treatment</p>	<p>Understanding safety precaution and Personal Protective Equipment for heat treatment processes Understand heat treatment, its purpose methods and their application Basic knowledge about materials and their heat treatment requirements Understand furnace operation (vacuum furnace, conveyor belt furnace, conventional heating furnace, annealing furnace) Basic information about commonly used quenching media (Diesel, Water, quenching oil etc) Understand usage of Rockwell Hardness Tester (scale C) Understand basic concepts of hardness and brittleness</p>	<p>Annealing Furnace Conventional Heating Furnace Vacuum Furnace Conveyor Belt Furnace Rockwell Hardness Tester Standard chart of materials (Regarding heat treatment) Quenching Tank Consumable: First aid box with complete accessories Personal protective equipment (Helmets, Safety Goggles, safety gloves, Safety Shoe, Face mask, Apron, etc.) work piece Furnace oil/ natural gas (For heating furnace) Quenching media (Diesel, Water, quenching oil etc) Process travel card</p>

Learning Unit	Learning Outcomes	Learning Elements	Materials Required
<p>LU2: Perform annealing</p>	<p>The learner will be able to:</p> <p>Set furnace parameters (temperature, time) as per material requirements</p> <p>Place work pieces inside the annealing furnace to achieve set temperature</p> <p>Switch off the furnace and let work pieces cool down to room temperature inside the furnace (12 to 15 hours)</p> <p>Remove work pieces from furnace, test hardness of work pieces using Rockwell Hardness Tester as per hardness requirements and prepare test report</p>	<p>Understand health and safety requirements of annealing processes</p> <p>Understand annealing, its purpose, method and their application</p> <p>Understanding about standard operating procedures of annealing furnace</p> <p>Basic knowledge about materials and their annealing requirements</p> <p>Understand usage of Rockwell Hardness Tester (scale C)</p> <p>Understanding of handling methods of annealed work piece</p> <p>Understanding of time management</p> <p>Understanding of contingency management</p> <p>Understand the defects of annealed work piece (Oxidation, Bending, improper annealed etc) and its corrective measures</p>	<p>Annealing Furnace</p> <p>Basket (to carry work piece in annealing furnace)</p> <p>Rockwell Hardness Tester</p> <p>Standard chart of materials (Regarding annealing)</p> <p>Consumable:</p> <p>First aid box with complete accessories</p> <p>Personal protective equipment (Helmets, Safety Goggles, safety gloves, Safety Shoe, Face mask, Apron, etc.)</p> <p>work piece</p> <p>Furnace oil/ natural gas (For heating furnace)</p> <p>Process travel card</p>

Learning Unit	Learning Outcomes	Learning Elements	Materials Required
		Understanding PTC (process travelling card) and its applications (Storage of job, quality, quantity etc)	
LU3: Apply heat treatment by conventional method	The learner will be able to: Set furnace parameters (temperature, time) as per material requirements Maintain flame quality by adjusting Air: Fuel ratio to avoid carbon deposits on instruments Hold work pieces with wires and place in the furnace for specified time Remove work pieces safely from furnace and quench in quenching medium (air, water & oil) for specified time	Understand health and safety requirements of conventional heat treatment method processes Understand conventional heat treatment, its purpose, method and their application Understanding about standard operating procedures of conventional heat treatment furnace Understanding flame types and their effects on conventional heat treatment (Reducing, Neutral and oxidizing flame) Basic knowledge about materials and their conventional heat treatment requirements Basic information about commonly used quenching media in conventional heat treatment Understand usage of Rockwell Hardness Tester (scale	Conventional Heating Furnace Rockwell Hardness Tester Hangers/ Baskets (to carry work pieces in furnace) Standard chart of materials Quenching Tank Consumable: First aid box with complete accessories Personal protective equipment (Helmets, Safety Goggles, safety gloves, Safety Shoe, Face mask, Apron, etc.) work piece Furnace oil/ natural gas (For heating furnace) Process travel card Quenching media (Diesel, Water, quenching oil etc) Process travel card Stainless steel wire (to hold the work pieces)

Learning Unit	Learning Outcomes	Learning Elements	Materials Required
	<p>Remove oil from quenched work pieces using appropriate method (draining by hanging and cleaning with cotton etc.)</p> <p>Perform acid pickling to remove the scales from surface of work pieces</p> <p>Test hardness of work pieces using Rockwell Hardness Tester as per hardness requirements and prepare test report</p>	<p>C)</p> <p>Understanding of handling methods of conventional heat treatment work piece</p> <p>Understanding of time management</p> <p>Understanding of contingency management</p> <p>Understand the defects of conventional heat treatment work piece (Oxidation, improper hardened etc) and its corrective measures</p> <p>Understanding PTC (process travelling card) and its applications (Storage of job, quality, quantity etc)</p>	
<p>LU4: Apply Vacuum heat treatment</p>	<p>The learner will be able to:</p> <p>Use appropriate methods and equipment to serve food and accompaniments to guests in different settings</p> <p>Prepare and serve drinks to guests in different settings</p> <p>Maintain the food and beverage service throughout the shift</p> <p>Demonstrate safe and hygienic working practices</p>	<p>Understand health and safety requirements of Vacuum heat treatment processes</p> <p>Understand Vacuum heat treatment, its purpose, method and their application</p> <p>Understanding about standard operating procedures of Vacuum heat treatment furnace</p>	<p>Vacuum Furnace</p> <p>Rockwell Hardness Tester</p> <p>Hangers/ Baskets (to carry work pieces in furnace)</p> <p>Standard chart of materials</p> <p>Consumable:</p> <p>First aid box with complete accessories</p> <p>Personal protective equipment (Helmets, Safety Goggles, safety gloves, Safety Shoe, Face mask, Apron, etc.)</p>

Learning Unit	Learning Outcomes	Learning Elements	Materials Required
	<p>when serving food, accompaniments, and beverages to guests</p> <p>Store food and equipment safely in line with organizational requirements</p> <p>Dispose of waste in line with organizational requirements</p> <p>Deal with unexpected situations in line with organizational guidelines</p>	<p>Basic knowledge about materials and their Vacuum heat treatment requirements</p> <p>Basic information about commonly used cooling media in Vacuum heat treatment (Nitrogen etc)</p> <p>Understand usage of Rockwell Hardness Tester (scale C)</p> <p>Understanding of handling methods of Vacuum heat treatment work piece</p> <p>Understand the defects of Vacuum heat treatment work piece (improper hardened etc) and its corrective measures</p> <p>Understanding PTC (process travelling card) and its applications (Storage of job, quality, quantity etc)</p>	<p>work piece</p> <p>Process travel card</p> <p>Cooling media (Nitrogen etc)</p> <p>Process travel card</p> <p>Stainless steel wire (to hold the work pieces)</p>
<p>LU5: Apply Conveyor Belt Heat Treatment</p>	<p>The learner will be able to:</p> <p>Prepare vacuum furnace (temperature, time, speed) as per material requirements</p> <p>Place the work pieces on conveyor belt of the furnace</p>	<p>Understand health and safety requirements of Conveyor Belt Heat Treatment processes</p> <p>Understand Conveyor Belt Heat Treatment, its purpose, method and their application</p> <p>Understanding about standard operating procedures of</p>	<p>Notepads</p> <p>Pen</p> <p>Calculators</p> <p>Check folders</p> <p>Cash till (mechanical/ electronic)</p> <p>Cash float</p> <p>Mechanism for keeping cash secure</p> <p>Guest comment cards</p> <p>Cash summary sheets</p>

Learning Unit	Learning Outcomes	Learning Elements	Materials Required
	<p>and start the process</p> <p>Remove work pieces from furnace, test hardness of work pieces using Rockwell Hardness Tester as per hardness requirements and prepare test report</p>	<p>Conveyor Belt Heat Treatment furnace</p> <p>Basic knowledge about materials and their Conveyor Belt Heat Treatment requirements</p> <p>Basic information about commonly used cooling media in Conveyor Belt Heat Treatment (Nitrogen etc)</p> <p>Understand usage of Rockwell Hardness Tester (scale C)</p> <p>Understanding of handling methods of Conveyor Belt Heat Treatment work piece</p> <p>Understand the defects of Conveyor Belt Heat Treatment (improper hardened, bending etc) and its corrective measures</p> <p>Understanding PTC (process travelling card) and its applications (Storage of job, quality, quantity etc)</p>	<p>Error slips</p> <p>Computer, accessories, software</p> <p>Work area log for recording problems, suspicious items, lost property and unexpected situations</p> <p>Waiter's uniform according to job requirements (black trousers, white shirt, black socks, black shoes, tie (appropriate to the organization), jacket (appropriate to the organization)</p>

Videos

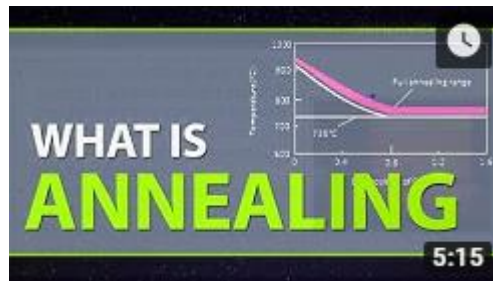

How to perform Annealing process?

<https://www.youtube.com/watch?v=GnCaCXNTNgw>

<https://www.youtube.com/watch?v=buxW1vdrBXQ>

<https://www.youtube.com/watch?v=zrK3yR2mAoU>

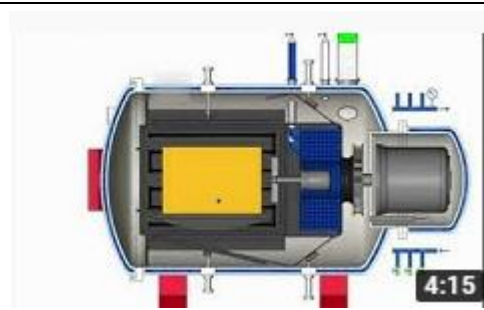

How to perform heat treatment conventional method?

<https://www.youtube.com/watch?v=8g7lglfC4dU>

<https://www.youtube.com/watch?v=zPhBlaGG7sw>



How to perform Conveyor belt heat treatment process?

<https://www.youtube.com/watch?v=6CRYPkbJQjI>

<https://www.youtube.com/watch?v=27uWTNG81fM>



How to operate a Rockwell Hardness taster?

Understand usage of Rockwell Hardness Tester (scale C)

https://www.youtube.com/watch?v=NIWVmp_q_XE

<https://www.youtube.com/watch?v=gZLULc3GgaA>

Examples and illustration

Perform Annealing:

Method:

Forged surgical instruments are then annealed in vacuum furnaces. These furnaces are typically batch-furnaces where batches of forged instruments are annealed under vacuum to prevent corrosion. Annealing is a process which makes Stainless Steel soft for machining.

In metallurgy and materials science, annealing is a heat treatment that alters the physical and sometimes chemical properties of a material to increase its ductility and reduce its hardness, making it more workable.

In annealing, atoms migrate in the crystal lattice and the number of dislocations decreases, leading to a change in ductility and hardness. As the material cools it recrystallizes. For many alloys, including carbon steel, the crystal grain size and phase composition, which ultimately determine the material properties, are dependent on the heating rate and cooling rate. Hot working or cold working after the annealing process alter the metal structure, so further heat treatments may be used to achieve the properties required. With knowledge of the composition and phase diagram, heat treatment can be used to adjust from harder and more brittle to softer and more ductile.

In the cases of copper, steel, silver, and brass, this process is performed by heating the material (generally until glowing) for a while and then slowly letting it cool to room temperature in still air. Copper, silver and brass can be cooled slowly in air, or quickly by quenching in water, unlike ferrous metals, such as steel, which must be cooled slowly to anneal. In this fashion, the metal is softened and prepared for further work such as shaping, stamping, or forming.

Normalization is an annealing process applied to ferrous alloys to give the material a uniform fine-grained structure and to avoid excess softening in steel. It involves heating the steel to 20–50 °C above its upper critical point, soaking it for a short period at that temperature and then allowing it to cool in air. Heating the steel just above its upper critical point creates austenitic grains (much smaller than the previous ferritic grains), which during cooling, form new ferritic grains with a further refined grain size. The process produces a tougher, more ductile material, and eliminates columnar grains and dendritic segregation that sometimes occurs during casting. Normalizing improves machinability of a component and provides dimensional stability if subjected to further heat treatment processes.

A full anneal typically results in the second most ductile state a metal can assume for metal alloy. Its purpose is to originate a uniform and stable microstructure that most closely resembles the metal's phase diagram equilibrium microstructure, thus letting the metal attain relatively low levels of hardness, yield strength and ultimate strength with high plasticity and toughness. To perform a full anneal on a steel for example, steel is heated to slightly above the austenitic temperature and held for sufficient time to allow the material to fully form austenite or austenite-cementite grain structure. The material is then allowed to cool very slowly so that the equilibrium microstructure is obtained. In most cases this

means the material is allowed to furnace cool (the furnace is turned off and the steel is let cool down inside) but in some cases it is air cooled. The cooling rate of the steel has to be sufficiently slow so as to not let the austenite transform into bainite or martensite, but rather have it completely transform to pearlite and ferrite or cementite. This means that steels that are very hardenable (i.e. tend to form martensite under moderately low cooling rates) have to be furnace cooled. The details of the process depend on the type of metal and the precise alloy involved. In any case the result is a more ductile material but a lower yield strength and a lower tensile strength. This process is also called LP annealing for *lamellar pearlite* in the steel industry as opposed to a *process anneal*, which does not specify a microstructure and only has the goal of softening the material. Often the material to be machined is annealed, and then subject to further heat treatment to achieve the final desired properties.

Apply Conveyor Belt Heat Treatment

Method:

A **conveyor belt furnace** is a furnace uses a conveyor or belt to carry process parts or material through the primary heating chamber for rapid thermal processing. It is designed for fast drying and curing of products and is nowadays widely used in the firing process of thick film and metallization process of solar cell manufacturing. Other names for conveyor belt furnace include metallization furnace, belt furnace, atmosphere furnace, infrared furnace and fast fire furnace, to just list a few.

Normally a conveyor furnace adopts a tunnel structure and is composed of multiple controlled zones which include zones for preheating, binder burn out, heating, firing, and cooling. A conveyor furnace also features fast thermal responses, uniform and stable temperature distribution; it can heat treated parts to 1050 deg. C. (may vary for different model). Belt speed of a conveyor furnace can be up to 6000mm/min. Products are

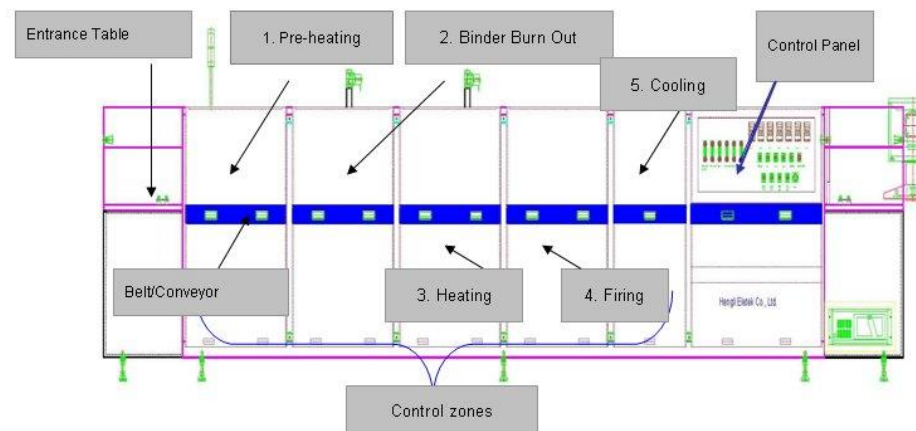

1. heating section
2. Binder burn out section
3. Heating section

4. Firing section
5. Cooling section

HOW A CONVEYOR FURNACE WORKS

A conveyor furnace is designed for the rapid heat treatment of products in various manufacturing environments. They comprise an overarching tunnel-shaped heating chamber which is separated into different heating modules which integrate several heating processes into one continuous procedure, using a conveyor belt capable of withstanding extreme and fluctuating temperatures. The internal heating modules are typically separated into sections for pre-heating, heating and / or firing, and cooling products passing through the chamber. Each of these sections must perform to varying specifications, requiring exceptional thermal insulation and efficient heating elements capable of treating components or products at temperatures of up to 1832°F (1000°C).

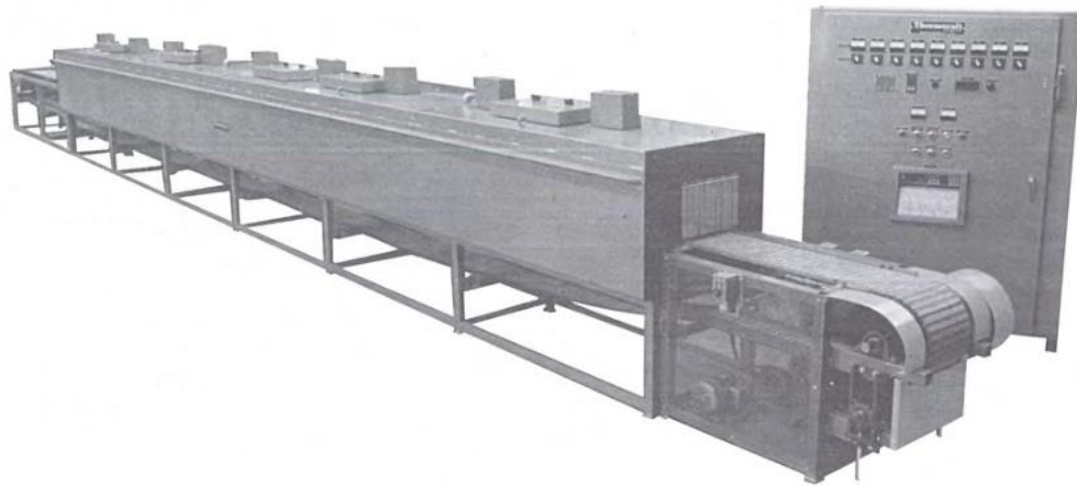

Module Summery

Module	Learning Unit	Duration
<p>Module 1: Perform Forging Aim: The aim of this module to develop the knowledge, skills and understanding needed to perform forging</p>	<p>LU1: Perform Sheet Cutting LU2: Apply hammer stroke LU3: Trim extra material</p>	<p>130 hours</p>

Module	Learning Unit	Duration
<p>Module 2: Perform Manual Machining</p> <p>Aim: The aim of this module to develop the knowledge, skills and understanding needed to perform manual machining</p>	<p>LU1: Perform turning operations LU2: Perform milling operations</p>	130 hours
<p>Module 3: Develop Sheet Metal Surgical Instruments</p> <p>Aim: The aim of this module to develop the knowledge, skills and understanding needed to develop sheet metal surgical instruments</p>	<p>LU1: Perform blanking LU2: Perform punching LU3: Perform bending</p>	130 hours
<p>Module 4: Apply Heat Treatment</p> <p>Aim: The aim of this module to develop the knowledge, skills and understanding needed to apply heat treatment</p>	<p>LU1: Prepare workstation for heat treatment LU2: Perform annealing LU3: Apply heat treatment by conventional method LU4: Apply Vacuum heat treatment LU5: Apply Conveyor Belt Heat Treatment</p>	150 hours

Frequently ask question

<p>1. What is Competency Based Training (CBT) and how is it different from currently offered trainings in institutes?</p>	<p>Competency-based training (CBT) is an approach to vocational education and training that places emphasis on what a person can do in the workplace as a result of completing a program of training. Compared to conventional programs, the competency based training is not primarily content based; it rather focuses on the competence requirement of the envisaged job role. The whole qualification refers to certain industry standard criterion and is modularized in nature rather than being course oriented.</p>
<p>2. What is the passing criterion for CBT certificate?</p>	<p>You shall be required to be declared “Competent” in the summative assessment to attain the certificate.</p>
<p>3. What are the entry requirements for this course?</p>	<p>The entry requirement for this course is 8th Grade or equivalent.</p>
<p>4. How can I progress in my educational career after attaining this certificate?</p>	<p>You shall be eligible to take admission in the National Vocational Certificate Level-3 in Fan Manufacturing Technician (Assembler). You shall be able to progress further to National Vocational Certificate Level-4 in Fan Manufacturing Technician (Supervisor); and take admission in a level-5, DAE or equivalent course. In certain case, you may be required to attain an equivalence certificate from The Inter Board Committee of Chairmen (IBCC).</p>
<p>5. If I have the experience and skills mentioned in the competency standards, do I still need to attend the course to attain this certificate?</p>	<p>You can opt to take part in the Recognition of Prior Learning (RPL) program by contacting the relevant training institute and getting assessed by providing the required evidences.</p>
<p>6. What is the entry requirement for Recognition of Prior Learning program (RPL)?</p>	<p>There is no general entry requirement. The institute shall assess you, identify your competence gaps and offer you courses to cover the gaps; after which you can take up the final assessment.</p>

7. Is there any age restriction for entry in this course or Recognition of Prior Learning program (RPL)?	There are no age restrictions to enter this course or take up the Recognition of Prior Learning program
8. What is the duration of this course?	The duration of the course work is
9. What are the class timings?	The classes are normally offered 25 days a month from 08:00am to 01:30pm. These may vary according to the practices of certain institutes.
10. What is equivalence of this certificate with other qualifications?	As per the national vocational qualifications framework, the level-4 certificate is equivalent to Matriculation. The criteria for equivalence and equivalence certificate can be obtained from The Inter Board Committee of Chairmen (IBCC).
11. What is the importance of this certificate in National and International job market?	This certificate is based on the nationally standardized and notified competency standards by National Vocational and Technical Training Commission (NAVTTTC). These standards are also recognized worldwide as all the standards are coded using international methodology and are accessible to the employers worldwide through NAVTTTC website.
12. Which jobs can I get after attaining this certificate? Are there job for this certificate in public sector as well?	You shall be able to take up jobs in the fan manufacturing industries in the functions of packing and painting of fans.
13. What are possible career progressions in industry after attaining this certificate?	You shall be able to progress up to the level of supervisor after attaining sufficient experience, knowledge and skills during the job. Attaining additional relevant qualifications may aid your career advancement to even higher levels.
14. Is this certificate recognized by any competent authority in Pakistan?	This certificate is based on the nationally standardized and notified competency standards by National Vocational and Technical Training Commission (NAVTTTC). The official certificates shall be awarded by the relevant certificate awarding body.

15. Is on-the-job training mandatory for this certificate? If yes, what is the duration of on-the-job training?	On-the-job training is not a requirement for final / summative assessment of this certificate. However, taking up on-the-job training after or during the course work may add your chances to get a job afterwards.
16. How much salary can I get on job after attaining this certificate?	The minimum wages announced by the Government of Pakistan in 2019 are PKR 17,500. This may vary in subsequent years and different regions of the country. Progressive employers may pay more than the mentioned amount.
17. Are there any alternative certificates which I can take up?	There are some short courses offered by some training institutes on this subject. Some institutes may still be offering conventional certificate courses in the field.
18. What is the teaching language of this course?	The teaching language of this course is Urdu and English.
19. Is it possible to switch to other certificate programs during the course?	There are some short courses offered by some training institutes on this subject. Some institutes may still be offering conventional certificate courses in the field.
20. What is the examination / assessment system in this program?	Competency based assessments are organized by training institutes during the course which serve the purpose of assessing the progress and preparedness of each student. Final / summative assessments are organized by the relevant qualification awarding bodies at the end of the certificate program. You shall be required to be declared "Competent" in the summative assessment to attain the certificate.
21. Does this certificate enable me to work as freelancer?	You can start your small business of stitching leather garments, gloves or other products. You may need additional skills on entrepreneurship to support your initiative.

22. Why wear personal protective equipment's in surgical manufacturing?

<https://www.fda.gov/medical-devices/general-hospital-devices-and-supplies/personal-protective-equipment-infection-control>

Personal protective equipment (PPE) refers to protective clothing, helmets, gloves, face shields, goggles, facemasks and/or respirators or other equipment designed to protect the wearer from injury or the spread of infection or illness.

PPE is commonly used in health care settings such as hospitals, doctor's offices and clinical labs. When used properly, PPE acts as a barrier between infectious materials such as viral and bacterial contaminants and your skin, mouth, nose, or eyes (mucous membranes). The barrier has the potential to block transmission of contaminants from blood, body fluids, or respiratory secretions. PPE may also protect patients who are at high risk for contracting infections through a surgical procedure or who have a medical condition, such as, an immunodeficiency, from being exposed to substances or potentially infectious material brought in by visitors and healthcare workers. When used properly and with other infection control practices such as hand-washing, using alcohol-based hand sanitizers, and covering coughs and sneezes, it minimizes the spread of infection from one person to another. Effective use of PPE includes properly removing and disposing of contaminated PPE to prevent exposing both the wearer and other people to infection.

<p>23. What the FDA's role in regulating personal protective equipment?</p> <p>https://www.fda.gov/medical-devices/general-hospital-devices-and-supplies/personal-protective-equipment-infection-control</p>	<p>All personal protective equipment (PPE) that is intended for use as a medical device must follow FDA's regulations and should meet applicable voluntary consensus standards for protection. This includes surgical masks, N95 respirators, medical gloves, and gowns. The consensus standards and FDA's requirements vary depending on the specific type of PPE. When these standards and regulations are followed, they provide reasonable assurance that the device is safe and effective.</p>
<p>24. What is surgical instruments manufacturing process?</p> <p>http://cdi.psic.gov.pk/reports/surgical/The%20Manufacturing%20Process.pdf</p> <p>http://vetfolio-vetstreet.s3.amazonaws.com/eb/951a30334a11e29e50005056ad4736/file/VT1212_Price_CE.pdf</p>	<p>The selection and use of quality surgical instruments are key components in providing safe, efficient and cost effective patient care in the operating room (OR). Quality instrument manufacturing involves standards for various aspects of the manufacturing process, including the basic requirements for the quality of stainless steel used, as well as quality control inspections used at every step in the process. Despite the existence of these standards, perioperative professionals are still confronted with surgical instruments of varying quality levels, depending on the individual quality standards of the instrument manufacturer. Therefore, it is important that members of the Sterile Processing and perioperative teams involved in the selection and use of surgical instrumentation understand the variations in instrument manufacturing processes, in order to provide the best possible instruments for patient care. This continuing education activity will provide a review of the key considerations in the quality manufacturing process for premier OR grade surgical instruments. A brief overview of the historical evolution of surgical instruments will be presented. The key components of premier quality stainless steel used in the manufacture of surgical instruments will be discussed. The United States requirements for stainless steel surgical instrument package labeling will be outlined, including the definition of country of origin. The steps in the manufacturing process of high quality surgical instruments will be described in detail. The clinical considerations related to the selection and use of quality premier OR grade instruments, and the importance</p>

	<p>of the facility's water quality in maintaining quality surgical instruments, will be presented.</p>
<p>25. How to Safe management of wastes from health-care activities? http://www.searo.who.int/srilanka/documents/safe_management_of_wastes_from_healthcare_activities.pdf</p>	<p>This is the second edition of the World Health Organization (WHO) handbook on the safe, sustainable and affordable management of health-care waste – commonly known as “the Blue Book”. The original Blue Book was a comprehensive publication used widely in health-care centers and government agencies to assist in the adoption of national guidance. It also provided support to committed medical directors and managers to make improvements and presented practical information on waste-management techniques for medical staff and waste workers. The first edition in 1999 was published at an influential point in time. Public interest in emerging and developing countries to improve health services was growing, and poor waste practices within health-care facilities were being challenged increasingly by interest groups and communities. In the more developed countries, there was a renewed concern about consumption of resources and impacts on global changes to climate and the environment. In many countries, knowledge about the potential for harm from health-care wastes has now become more prominent to governments, medical practitioners and civil society. Increasingly, managers and medical staff are expected to take more responsibility for the wastes they produce from their medical care and related activities. The indiscriminate and erratic handling and disposal of waste within health-care facilities is now widely recognized as a source of avoidable infection, and is synonymous with public perception of poor standards of health care.</p>
<p>26. What is the best practice for disposing of waste? https://www.nibusinessinfo.co.uk/content/waste-disposal-best-practice</p>	<p>In general terms you must:</p> <ul style="list-style-type: none"> • identify your source and type of waste accurately • complete waste disposal documentation such as transfer, duty of care notes or hazardous waste consignment notes • find a registered carrier to transport your waste

	<ul style="list-style-type: none">• store the waste safely and securely until it is removed• dispose of waste only at facilities that are licensed to accept that type of material
<p>27. How To Achieve Perfect Medical devices. https://www.youtube.com/watch?v=aL_FHZ75-XQ</p>	

Test Yourself (Multiple Choice Questions)

MODULE 1

Question 1 Shearing the sheet into two or more pieces is known as?

A Perforating

B Parting

C Notching

D Lancing

Question 2 Removing the pieces from the edge in shearing operation is known as?

A Perforating

B Parting

C Notching

D Lancing

- Question 3** Which **TWO** of the following are most important when taking guests' orders?
- A Checking that the guest has a reservation
 - B Choosing the right time to take the order
 - C Asking the kitchen if they are ready for service
 - D Being patient with indecisive guests

- Question 4** Which of the following forming processes is suitable for making utensils and cup shaped objects?
- A Forging
 - B Rolling
 - C Deep drawing
 - D Wire drawing

- Question 5** In deep or cup drawing, maximum tensile stress is caused near the end of punch.
- A True
 - B False

MODULE 2

- Question 6** Grain number of grinding wheel is ___ to grain size.
- A Directly proportional
 - B Inversely proportional
 - C Does not depend
 - D None of the mentioned
- Question 7** Which of the following grinding machine will give a better result for rough machining?
- A Fine grain
 - B Very fine grain
 - C Coarse grain
 - D None of the mentioned

Question 8 Multi spindle drilling machine is used for lot production.

A True

B False

Question 9 Multi spindle drill machines can produce holes of different_____

A Shapes

B Shapes

C Both shapes and depth

D None of the mentioned

Question 10 Which of the following is the part of multi spindle drill machine?

A Motor

B Central gear

C Planetary gear

D All of the mentioned

MODULE 3

Question 11 Which of the following is the hardest constituent of steel?

A Ledeburite

B Austenite

C Bainite

D Martensite

Question 12 Annealing of steel is done to impart which one of the following properties on steel?

A Hardness

B Toughness

C Ductility

D None of the mentioned

- Question 13** Mild steel can be converted into high carbon steel by using which of the following process?
- A Annealing
 - B Normalizing
 - C Case hardening
 - D None of the mentioned

- Question 14** In Annealing cooling is done in which of the following medium?
- A Air
 - B Water
 - C Oil
 - D Furnace

Question 15 In Normalizing cooling is done in which of the following medium?

A Air

B Water

C Oil

D Furnace

Question 16 Hypoeutectoid steels on cooling during annealing process converts to:

A Perlite

B Cementite

C Austenite

D None of the mentioned

Question 17 Which of the following processes will one use on hardened steel to reduce brittleness?

A Annealing

B Normalizing

C Spheroidizing

D Tempering

Question 18 Which of the following alloying element can be used to deoxidize steels?

A Phosphorous

B Carbon

C Cerium

D Selenium

Question 19 Which of the following is defined as the ability of the structure to transform into martensite?

A Hardenability

B Strength

C Toughness

D Hardness

Question 20 Which of the following has the highest hardness number?

A Martensite

B Tempered martensite

C Pearlite

D Fine pearlite

Answers

MODULE 1

- Question 1** Which type of metal is used in casting process? A Liquid
- Question 2** The casting can be defined as pouring of molten metal into a mould and taking it out after it becomes vapor B False
- Question 3** Which of the following is the component of foundry sand? D All of the mentioned
- Question 4** Which of the following component withstand the high temperature in casting process? C Silica
- Question 5** Why the porous structure provided by the silica is necessary in casting process? C For the escape of both gases and vapors
- Question 6** Cold forging is also known as simply forging. B False
- Question 8** In forging process, metals are shaped by A Impact
- Question 9** Which type of forging is done by deforming the metal at room temperature? A Cold forging
- Question 10** Hot forging is also known as simply forging. B True

MODULE 2

- Question 11** Which type of lathe is also known as center lathe? C Engine lathe
- Question 12** Which of the following is the example of speed lathe? B Polishing lathe
- Question 13** Which of the following is the base of the lathe machine? A Bed
- Question 14** Which of the following is fitted on the bed? D Headstock and tailstock both
- Question 15** Which of the following is not the part of the bed? D None of the mentioned
- Question 16** Milling cutters may be made of ferrous cast alloys. B True
- Question 17** The cutting elements intermittently engages C Both workpiece and remove material
- Question 18** Which of the following is not the part of spindle? D None of the mentioned
- Question 19** Offset of tailstock is done for A Taper turning
- Question 20** The various milling process may be classified in _____ categories. B 2

MODULE 3

- Question 21** Shearing the sheet into two or more pieces is known as? B Parting
- Question 22** Removing the pieces from the edge in shearing operation is known as? C Notching
- Question 23** Which **TWO** of the following are most important when taking guests' orders? B Choosing the right time to take the order
- Question 24** Which of the following forming processes is suitable for making utensils and cup shaped objects? B Deep drawing
- Question 25** In deep or cup drawing, maximum tensile stress is caused near the end of punch. A True

MODULE 4

- Question 26** Grain number of grinding wheel is ___ to grain size. A Inversely proportional
- Question 27** Which of the following grinding machine will give a better result for rough machining? B Coarse grain
- Question 28** Multi spindle drilling machine is used for lot production. A True
- Question 29** Multi spindle drill machines can produce holes of different_____. C Both shapes and depth
- Question 30** Which of the following is the part of multi spindle drill machine? D All of the mentioned

MODULE 5

- Question 31** Which of the following is the hardest constituent of steel? D Martensite
- Question 32** Annealing of steel is done to impart which one of the following properties on steel? C Ductility
- Question 33** Mild steel can be converted into high carbon steel by using which of the following process? C Case hardening
- Question 34** In Annealing cooling is done in which of the following medium? D Furnace
- Question 35** In Normalizing cooling is done in which of the following medium? A Air
- Question 36** What does the term 'yield management' mean in accommodation and front office situations? A Perlite
- Question 37** Which of the following processes will one use on hardened steel to reduce brittleness? D Tempering
- Question 38** Which of the following alloying element can be used to deoxidize steels? C Cerium
- Question 39** Which of the following is defined as the ability of the structure to transform into martensite? A Hardenability
- Question 40** Which of the following has the highest hardness number? A Martensite

National Vocational and Technical Training Commission (NAVTTTC)

 Plot 38, Kirthar Road, Sector H-9/4, Islamabad, Pakistan

 +92 51 9044 322

 +92 51 9044 322

 info@navttc.org

 www.navttc.org