



Co-funded by the European Union



Norwegian Embassy
Islamabad



© TVET SSP

POST PRESS OPERATIONS (Publishing)

Learner Guide

National Vocational Certificate Level 3

Version 1 - December 2019



Implemented by

giz Deutsche Gesellschaft
für Internationale
Zusammenarbeit (GIZ) GmbH

Published by

National Vocational and Technical Training Commission
Government of Pakistan

Headquarter

Plot 38, Kirthar Road, Sector H-9/4, Islamabad, Pakistan
www.navttc.org

Responsible

Director General Skills Standard and Curricula, National Vocational and Technical Training Commission
National Deputy Head, TVET Sector Support Programme, Deutsche Gesellschaft für Internationale Zusammenarbeit (GIZ) GmbH

Layout & design

SAP Communications

Photo Credits

TVET Sector Support Programme

URL links

Responsibility for the content of external websites linked in this publication always lies with their respective publishers. TVET Sector Support Programme expressly dissociates itself from such content.

This document has been produced with the technical assistance of the TVET Sector Support Programme, which is funded by the European Union, the Federal Republic of Germany and the Royal Norwegian Embassy and has been commissioned by the German Federal Ministry for Economic Cooperation and Development (BMZ). The Deutsche Gesellschaft für Internationale Zusammenarbeit (GIZ) GmbH in close collaboration with the National Vocational and Technical Training Commission (NAVTTTC) as well as provincial Technical Education and Vocational Training Authorities (TEVTAs), Punjab Vocational Training Council (PVTC), Qualification Awarding Bodies (QABs)s and private sector organizations.

Document Version

December, 2019
Islamabad, Pakistan

POST PRESS OPERATIONS (Publishing)

Learner Guide

National Vocational
Certificate Level 3

Version 1 - December 2019

Introduction:

This Learner's Guide is developed on the basis of competency standards and curriculum of "Post Press Operations".

The National Vocational & Technical Training Commission (NAVTTTC) has developed a national qualification entitled, "National Vocational Certificate Level-3 in Post press Operations (Binder)". Relevant industry and employers were consulted in the design and validation processes in order to come up with a national qualification that fulfills the requirements of the sector in general and the occupation in particular.

This book covers all the topics in a clear and organized format for the Post Press students. Through learning outcomes practical activities were added step by steps. The topics covered were neatly illustrated for better understanding of the learners. All of the lesson pages were carefully designed to eliminate distraction and to focus the pupil's full attention on the work at hand.

It carries 5 learning modules which are as under:

- Module .1 Perform Gathering
- Module .2 Carry out Folding Operation
- Module .3 Perform Thread Stitch Binding
- Module .4 Perform Waste Management
- Module .5 Develop Professionalism

POST PRESS OPERATIONS (Publishing)

Learner Guide

National Vocational
Certificate Level 3

Version 1 - December 2019

Module-1

Module 1: - Perform Gathering

Learning Unit:

After completion of this module the learner will be able to:

- LU1: Perform substrate handling
- LU2: Verify form sequence
- LU3: Verify page number
- LU4: Pile up gathered forms
- LU5: Perform post production activity
- LU6: Maintain log book

Learning Unit-1 - : Perform Substrate handling

Overview: After successful completion of this learning unit, the student will be competent to handle substrate; numerical skills are underpinning knowledge and skills for the Competency Standard.

Define Importance of the substrate stacking

In this unit below element is very essential.

Printed form sequence: It's very important factor in substrate handling, because this element is ensure your page gathering sequence.

- **Paper handling:** it's pre requisite process to perform gathering operation.

Substrate: Substrate is used in a converting process such as printing or coating to generally describe the base material onto which, e.g. images, will be printed. Base materials may include: ... any variety of paper (lightweight, heavyweight, coated, uncoated, paperboard, cardboard, etc.), or. Parchment.

Method of checking substrate size:

- The paper size is mentioned on packing of paper ream for sheet-fed.
- The same can be verified through a full-size ruler by taking a sheet of paper from the ream and measuring it.

Substrate trimming procedure:



Paper Cutting Machine

In printing and finishing operations, the acts required to reduce sheets of paper (either blank or printed) to a desired size. Blank stock are often cut into sheets prior to shipping to a printer. Paper sheets need to be trimmed prior to printing to ensure that edges are perfectly square and straight to remove extra edges containing registration marks, etc.

Grain of substrate and its importance:

The grain direction of paper is an important factor to consider when planning your print projects. It affects how the paper prints, folds and binds. Simply put, paper folds and tears more easily with the grain than against. The grain direction is determined by the direction in which the paper fibers are aligned.

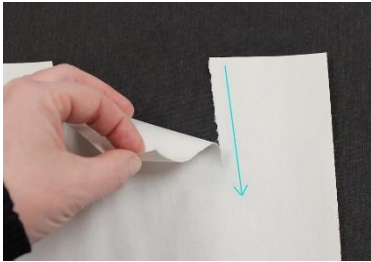

Right grain

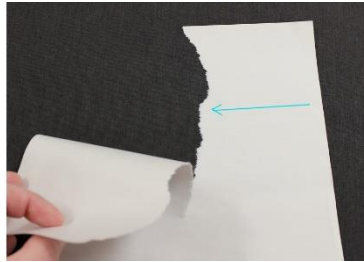

Wrong grain

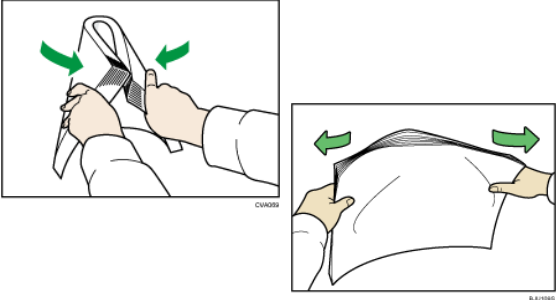

		Perform Gathering	
Module: 1	Learning Unit: 1	Perform Substrate Handling	
	Practical Description:	Verify binding side.	
Time:	8 hours		
Equipment	Lifter and stacker		
Tools	Dummy, folded form		
PPE	Safety shoes, helmet, Cover haul		
Materials	Cleaning Cloth, Cleaning brush		
Key Point	<ul style="list-style-type: none"> • Printed form sequence • Paper handling 		
Learning Outcome:	<ul style="list-style-type: none"> • Verify binding side as per docket/dummy. • Perform Substrate Stacking as per instruction/dummy. 		
Precautions:	Ensure to wear safety shoes and other safety equipment before starting this process		
Instructions		Illustrations	
1. Check binding side			

<p>2. Perform fanning</p>																									
<p>3. Paper feeding in machine</p>																									
<p>4. Set paper on machine according to the requirement</p>																									
<p>5. Perform test run and check the page number sequencing</p>	<table border="1" style="width: 100%; text-align: center;"> <thead> <tr> <th colspan="4">Front</th> <th colspan="4">Back</th> </tr> </thead> <tbody> <tr> <td>5</td> <td>12</td> <td>6</td> <td>8</td> <td>2</td> <td>01</td> <td>11</td> <td>6</td> </tr> <tr> <td>4</td> <td>13</td> <td>16</td> <td>1</td> <td>2</td> <td>15</td> <td>14</td> <td>3</td> </tr> </tbody> </table>	Front				Back				5	12	6	8	2	01	11	6	4	13	16	1	2	15	14	3
Front				Back																					
5	12	6	8	2	01	11	6																		
4	13	16	1	2	15	14	3																		



Learning Unit-2 - : Verify form sequence

Overview: After successful completion of this learning unit, the student will be competent to verify form sequence and numerical skills are underpinning knowledge and skills for the Competency Standard.

Describe binding and its type:

- **Sewn binding**
A strong, durable binding where inside pages are sewn together in sections. Standard thread color is white, but you can order different color threads.
- **PUR-glued**
Content pages are glued with PUR glue, which offers superior adhesion. Using smaller amounts of adhesive, it is more durable than hot melt binding. Once the glue is set, it is almost impossible to tear a page out.
- **Lay-flat binding**
Sewn soft cover books with endpapers, for which the cover spine is not attached to the book content spine part. This makes it possible for you to lay it flat when it is opened. This also gives the cover spine an appearance similar to hard cover books. When the book is opened, the cover does not crease in the direction of the spine.
- **Spiral**
Soft cover or hard cover books bound with spiral coil can open flat and offer 360-degree rotation. Spiral coils are available in different colors and sizes. Best results with products not thinner than 6mm and not thicker than 24mm.
- **Wire-o**
Punched pages are inserted onto a C-shaped wire spine, which is squeezed until it is round. Like spiral binding it can open flat, it offers 360-degree rotation and wires are available in different colors and sizes. Best results with soft or hard cover books not thinner than 2mm and not thicker than 24mm.
- **Saddle-stitched**
Most economical type of binding. Content pages and cover are stitched together with a metal wire, which is folded in the inside of the brochure and looks like a staple. 2 stitches is standard, but possible with more if requested.

Define Importance of form numbers: its pre requisite process to verify form sequence.

Perform Gathering		
Module: 1	Learning Unit: 2	Verify form sequence
	Practical Description:	Verify form sequence and binding side.
Time:	20 hours	
Equipment	N/A	
Tools	Dummy, folded form	
PPE	Safety shoes, helmet, Cover haul	
Materials	Cleaning Cloth, Cleaning brush	
Key Point	<ul style="list-style-type: none"> • Form sequence • Page number sequence • Verify with dummy/docket 	
Learning Outcome:	<ul style="list-style-type: none"> • Verify form number as per docket. • Arrange form sequence as per binding instruction. 	
Precautions:	Ensure to wear safety shoes and other safety equipment before starting this process	
Instructions		Illustrations
1. Stack forms at work station		
2. Place every form in sequence for easy gathering at arm length		

3. Develop a dummy





Learning Unit-3 - : Verify page number

Overview: After successful completion of this learning unit, the student will be competent to verify page numbers and numeric skills are underpinning knowledge and skills for the Competency Standard.

Define types of page numbers

Sometimes abbreviated as page no, a page number is the number of the specific page in a document. The document may be printed, like a book or a magazine. The page number is usually located at the bottom of the page, but sometimes can be found in the upper left or upper-right corner of the document. An example would be if a person reading a document is looking at the fifth page, that page is page number five.

In printed books, page number one is usually the first page of the first chapter in the book. The title page and table of contents are not included in the page numbering. However, in some professional documents, page number one is the title page.

		Perform Gathering	
Module: 1	Learning Unit: 3	Verify page number	
	Practical Description:	Verify page number sequence and get approval.	
Time:	20 hours		
Equipment	N/A		
Tools	Dummy, folded form		
PPE	Safety shoes, helmet, Cover haul		
Materials	Cleaning Cloth, Cleaning brush		
Key Point	<ul style="list-style-type: none"> • Page number sequence • Take approval from supervisor 		
Learning Outcome:	<ul style="list-style-type: none"> • Verify page number sequence as per dummy • Get approval of page sequence from supervisor 		
Precautions:	Ensure to wear safety shoes and other safety equipment before starting this process		
Instructions		Illustrations	
1. Stack forms at work station			
2. Place every form in sequence for easy gathering at arm length			

Learning Unit-4 - : Pile up gathered forms

Overview: After successful completion of this learning unit, the student will be competent to pile up the gathered forms and numeric skills are underpinning knowledge and skills for the Competency Standard.

Define gathering and identify its arrangements

It's all about the placement of printed forms of a book in correct order for binding.

Understand types of gathered form stacking

Gathered form stacking is based on binding type.

Describe binding and its type:

- **Sewn binding**

A strong, durable binding where inside pages are sewn together in sections. Standard thread color is white, but you can order different color threads.

- **PUR / Hot glued**

Content pages are glued with PUR or Hot glue, which offers superior adhesion. Using smaller amounts of adhesive, it is more durable than hot melt binding. Once the glue is set, it is almost impossible to tear a page out.

- **Lay-flat binding**

Sewn soft cover books with endpapers, for which the cover spine is not attached to the book content spine part. This makes it possible for you to lay it flat when it is opened. This also gives the cover spine an appearance similar to hard cover books. When the book is opened, the cover does not crease in the direction of the spine.

- **Spiral**



Soft cover or hard cover books bound with spiral coil can open flat and offer 360-degree rotation. Spiral coils are available in different colors and sizes. Best results with products not thinner than 6mm and not thicker than 24mm.

- **Wire-o**

Punched pages are inserted onto a C-shaped wire spine, which is squeezed until it is round. Like spiral binding it can open flat, it offers 360-degree rotation and wires are available in different colors and sizes. Best results with soft or hard cover books not thinner than 2mm and not thicker than 24mm.

- **Saddle-stitched**

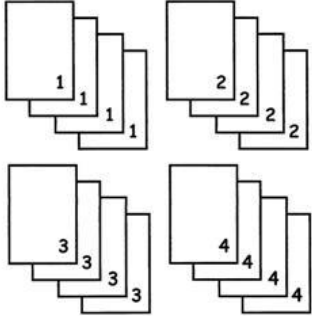
Most economical type of binding. Content pages and cover are stitched together with a metal wire, which is folded in the inside of the brochure and looks like a staple. 2 stitches is standard, but possible with more if requested.

		Perform Gathering	
Module: 1	Learning Unit: 4	Pile up gathered forms	
	Practical Description:	Verify pile up gathering	
Time:	18 hours		
Equipment	N/A		
Tools	Dummy, folded form		
PPE	Safety shoes, Cover haul		
Materials	Cleaning Cloth, Cleaning brush		
Key Point	<ul style="list-style-type: none"> • Page number sequence • Confirmation of binding side • Take approval from supervisor 		
Learning Outcome:	<ul style="list-style-type: none"> • Set gathered forms as per instruction • Perform gathering as per dummy. 		
Precautions:	Ensure to wear safety shoes and other safety equipment before starting this process		
Instructions		Illustrations	
1. Pile up gathering with page sequence			
2. Verify gathering as per dummy			

<p>3. Get approval from Supervisor</p>	
--	--

Learning Unit-5 - : Perform post production activity



Overview: After successful completion of this learning unit, the student will be competent to perform post production activity. Mathematical skills are underpinning knowledge and skills for the Competency Standard.

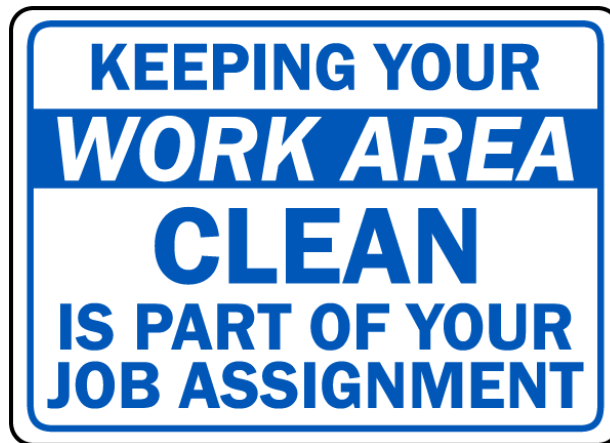

Importance of the cleaning after work

Cleaning and tidiness can help control or eliminate workplace hazards. Poor housekeeping practices frequently contribute to incidents.

Effective cleaning is an ongoing operation: it is not a one-time or hit-and-miss cleanup done occasionally. Periodic "panic" cleanups are costly and ineffective in reducing incidents.



		Perform Gathering	
Module: 1	Learning Unit: 5	Perform post production activity	
	Practical Description:	Cleaning of glue pot	
Time:	08 hours		
Equipment	Gathering machine		
Tools	Waste Cloth, Brush		
PPE	Safety shoes, helmet, Cover haul, Gloves		
Materials	Cleaning Cloth, ethanol or IPA		
Key Point	<ul style="list-style-type: none"> • Proper cleaning • Temperature control 		
Learning Outcome:	<ul style="list-style-type: none"> • Tie the gathered forms as per instruction • Clean workstation as per instruction 		
Precautions:	Ensure to wear safety shoes and other safety equipment before starting this process		
Instructions		Illustrations	
1. Switch on heater			
2. Set temperature as per requirement			

<p>3. Drain Glue</p>	
<p>4. Clean Glue tank with ethanol or IPA</p>	

Learning Unit-6 - : Maintain log book

Overview: The purpose of this learning unit is to inform the learner about importance of record keeping.

Importance of record keeping

The main reasons of record keeping are to ensure that quality assurance procedures are in place and operating satisfactorily and to record the daily amounts of production and rejection for use in financial accounting and record keeping. When raw materials are processed, each batch should be recorded in an Incoming Materials.

Records should also be kept of the amount and type of raw materials and customer wise.

Each day of production record keeping should be as per customer wise which is recorded in stock control books, processing logbooks and product sales records. The record keeping should be correlated with the product type that is printed on labels or outer cartons. This allows the processor to trace any subsequent faults in a batch of product back to the process or store.

		Perform Gathering	
Module: 1	Learning Unit: 6	Maintain log book	
	Practical Description:	Verify log book as per job	
Time:	06 hours		
Equipment	N/A		
Tools	Calculator, Measurement tape		
PPE	Safety shoes, Cover haul		
Materials	Note pad, Pen		
Key Point	<ul style="list-style-type: none"> • Daily Record keeping • Record keeping as per SOP 		
Learning Outcome:	<ul style="list-style-type: none"> • Record the final counter along-with the wastages • Record downtime during gathering operation 		
Precautions:	Ensure to wear safety shoes and other safety equipment before starting this process		
Instructions		Illustrations	
1. Note daily production			
2. Note daily rejection			

Summary of the Module:

In bookbinding, **gathering** refers to a group of sheets, folded in the middle, and bound into the binding together.

The section is the basic building block of codex bindings. In Western bookbinding, sections are sewn through their folds, with the sewing thread linking each section to its neighboring sections.

The gatherings can be seen by looking at the top or bottom sides of the book, though cheaper modern books are perfect bound with no gatherings, gluing each sheet directly to the binding. The gatherings are sewn into the binding and the middle sheet of each gathering will have two or more short stretches of thread visible at the central fold.

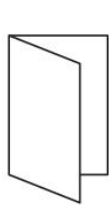

Half-Fold

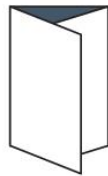
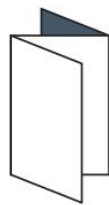
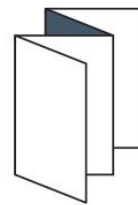
Tri-Fold
(3-Panel Roll Fold)Z-Fold
(3-Panel Accordion Fold)

4-Panel Accordion Fold

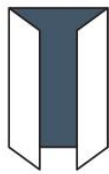

3-Panel Gate Fold



Double Gate Fold

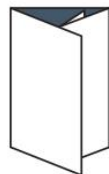

Roll Fold

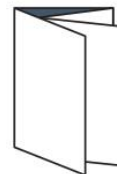

Double Parallel Fold



Vertical Half Fold

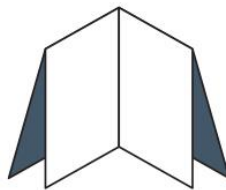

French Fold

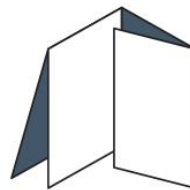

Map Fold

Frequently Asked Questions (FAQs)

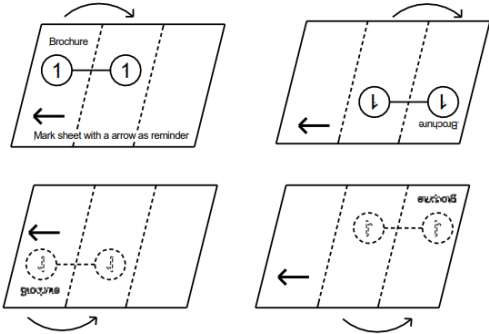
Question	Answer
1. How many types of gathering?	There are two types of gathering. <ol style="list-style-type: none"> 1. Hot glue 2. Saddle stitch
2. Why form sequence is important?	It's important to ensure the page number in order and in sequence; it's pre-requisite before of binding operation.
3. How many types of folding?	There are two types of folding. <ol style="list-style-type: none"> 1. Half fold 2. Tri fold (3 panel roll fold)
4. How many types of binding?	There are six types of binding. <ol style="list-style-type: none"> 1. Sewn binding 2. PUR-glued 3. Lay-flat binding 4. Spiral 5. Wire-o 6. Saddle-stitched
5. How will I load the feeder? 	Ans: There are four (4) choices here. You can load the feeder four different ways and the choice made will influence the fold plates you will be using. Each choice may have advantages or disadvantages. Some choices just will not work, so you can eliminate those choices right away. To start, make a choice, at this point it really doesn't matter which one, just remember how you started so you don't repeat it when making the next choice. I usually mark the paper with an ARROW to remind me how I started. After you choose work through the next question, then return to this question and make your next choice. Please try all 4 choices.
6. HOW SHOULD I SET EACH ROLLER?	Ans: Using the information from our previous steps we can now determine how to properly set each fold roller. You must set all the rollers even if you don't fold in all the plates. The paper passes through every roller. Set the roller to the MINIMUM thickness.

Self-Assessment

(MCQs)

Please mark the correct one from the given options. You can check your answer with the Answer Key at the end of this module

- Q 1. Which type of binding is correct?
- a) Spiral.
 - b) Form gathering.
 - c) Hard base.
 - d) None of above.
- Q 2. Why we use gathering of forms?
- a) For color management
 - b) Page sequence.
 - c) Die cutting.
 - d) Block making.
- Q 3. What will happen if form sequence is wrong?
- a) Client will accept.
 - b) Good printing quality.
 - c) Page sequence not correct.
 - d) Binding quality.
- Q 4. Which type of numbering is correct?
- a) Numeric numbering.
 - b) American numbering.
 - c) Urban numbering.
 - d) Track numbering.
- Q 5. Which one is the right purpose of gathering?
- a) Book binding.
 - b) Cloth binding.
 - c) Trade binding.
 - d) None of the above
- Q 6. The gathering style of saddle stitch and hot glue binding are same?
- a) True.
 - b) False.

- Q 7. Gathering is the essential part of book binding?
- a) True.
 - b) False.
- Q 8. Number written on forms helps in?
- a) Folding.
 - b) Binding.
 - c) Cutting.
 - d) Gathering sequence.
- Q 9. Gathering stack should be placed at what distance?
- a) 10 ft.
 - b) 20 ft.
 - c) 25 ft.
 - d) Arm's length
- Q 10. Ensuring sequence of the first pick is not important?
- a) True
 - b) False

Answer Key

MCQ No.	Correct Answer
1	A
2	B
3	C
4	A
5	A
6	B
7	A
8	D
9	D
10	B

POST PRESS OPERATIONS (Publishing)

Learner Guide

National Vocational
Certificate Level 3

Version 1 - December 2019

Module-2

Module 2: - Carry out Folding Operation

Learning Unit:

After completion of this module the learner will be able to:

- LU1: Perform substrate handling
- LU2: Make ready workstation for folding operation
- LU3: Perform Folding machine operation
- LU4: Perform post production activity
- LU5: Maintain log book

Learning Unit-1 - : Perform Substrate handling

Overview: After successful completion of this learning module, the student will be competent to perform substrate handling.

This learning unit, the student will be competent to handle substrate; numerical skills are underpinning knowledge and skills for the Competency Standard.

Define Importance of the substrate stacking

In this unit below element is very essential.

Printed form sequence: It's very important factor in substrate handling, because this element is ensure your page gathering sequence.

- **Paper handling:** it's pre requisite process to perform gathering operation.

Substrate: Substrate is used in a converting process such as printing or coating to generally describe the base material onto which, e.g. images, will be printed. Base materials may include: ... any variety of paper (lightweight, heavyweight, coated, uncoated, paperboard, cardboard, etc.), or. Parchment.

Method of checking substrate size:

- The paper size is mentioned on packing of paper ream for sheet-fed.
- The same can be verified through a full-size ruler by taking a sheet of paper from the ream and measuring it.

Substrate trimming procedure:



Paper Cutting Machine

In printing and finishing operations, the acts required to reduce sheets of paper (either blank or printed) to a desired size. Webs of blank stock are often cut into sheets prior to

shipping to a printer. (See Sheeting.) Paper sheets need to be trimmed prior to printing to ensure that edges are perfectly square and straight to remove extra edges containing registration marks, etc.

Grain of substrate and its importance:

The grain direction of paper is an important factor to consider when planning your print projects. It affects how the paper prints, folds and binds. Simply put, paper folds and tears more easily with the grain than against. The grain direction is determined by the direction in which the paper fibers are aligned.

Right grain Wrong grain

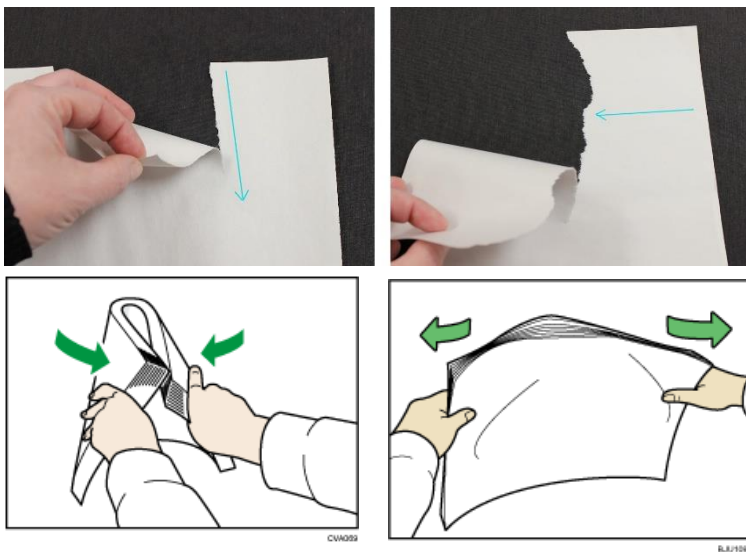

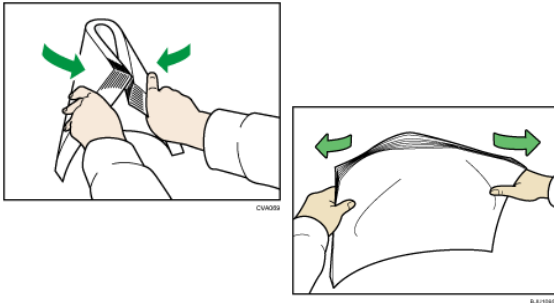
		Carry out Folding Operation	
Module: 2	Learning Unit: 1	Perform Substrate Handling	
	Practical Description:	Verify binding side.	
Time:	06 hours		
Equipment	Lifter and stacker		
Tools	Dummy, folded form		
PPE	Safety shoes, helmet, Cover haul		
Materials	Cleaning Cloth, Cleaning brush		
Key Point	<ul style="list-style-type: none"> • Printed form sequence • Paper handling 		
Learning Outcome:	<ul style="list-style-type: none"> • Verify side-lay & front-lay of substrate as per instruction. • Verify page number sequence as per dummy. 		
Precautions:	Ensure to wear safety shoes and other safety equipment before starting this process		
Instructions		Illustrations	
1. Check binding side			
2. Perform fanning			

3. Paper feeding in machine



4. Set paper on machine according to the requirement



5. Perform test run and check the page number sequencing

Front				Back			
5	21	6	8	2	01	11	6
4	13	16	1	2	15	14	3

Learning Unit-2 - : Make ready workstation for folding operation

Overview: After successful completion of this learning module, the student will be competent to perform to make ready work station for folding operation.

This learning unit, the student will be competent to make ready work station for folding operation; numerical skills are underpinning knowledge and skills for the Competency Standard.

Describe the importance of feeder

There are two types of feeders

- Friction feeder
- Vacuum feeder



Friction had become my friend and ally. When you look around the printing industry and the world at large you see that friction feeders are everywhere; in copy machines, laser and inkjet printers, collators, folding machines, inserters, folder gluers, packaging machinery, and more.

There **are** compelling reasons for this:

- They are relatively low cost. No pumps or sophisticated electronic controls are necessarily needed.
- They can feed bulky or oddly shaped materials that often can't be air fed.
- They can operate at extremely high speed for extended periods. Folder gluers in the packaging industry can routinely run at 50,000 to 100,000 pieces an hour.



The angle of the in feed table will affect feeder performance.

If your table is adjustable and you are having problems, you might want to experiment with different angles.

In feed guides will affect the sheet.

If they're too tight or too loose it won't feed properly. They should be set so that the sheet can move freely up and down the table without any twisting movement. This is especially important on the direct in-feed machines.

The paper itself can be the problem.







Paper has two sides, each with a different coefficient of friction. Inks, toners, varnishes and coatings will change the performance of the paper. The paper could be contaminated with paper dust from sheeting or cutting, or from press spray powder. Any of these can change throughout the run. Try flipping or rotating the sheet if you encounter a problem. I found that carefully applying a small amount of glycerin to the feed roller would often overcome spray powder or dust problems or problems with especially slick stocks.

Paper can scuff or scratch.

This is what gives friction feeders a bad name. Matte and dull coated stocks are especially sensitive to scuffing when rubbed. Yet friction feeders will handle a remarkable range of gloss coated stocks without any issues and uncoated stocks shouldn't be a problem. A common problem with uncoated stocks is that inks or toners that don't set or dry correctly and they offset on the sheet below. Rotating or flipping the sheet can help in these cases.



Activity: 1/2

Carry out Folding Operation		
Module: 2	Learning Unit: 2	Make ready workstation for folding operation
	Practical Description:	Perform the feeder and paper setting
Time:	20 hours	
Equipment	Lifter, Folding machine	
Tools	Allen key set, Screw Driver set, Spanner set, Grip Plier	
PPE	Safety shoes, helmet, Cover haul	
Materials	Cleaning Cloth, Paper.	
Key Point	<ul style="list-style-type: none"> • Describe the importance of feeder • Paper handling • Transfer belt and roller setting as per Paper GSM. 	
Learning Outcome:	<ul style="list-style-type: none"> • Adjust paper size on feeder as per substrate. • Pile up paper into the feeder. • Adjust feeder setting as per substrate • Adjust transfer rollers as per instruction • Adjust folding grill as per folding mark • Adjust folding knife on folding mark as per instruction. • Adjust transfer belt as per substrate. 	
Precautions:	Ensure to wear safety shoes and other safety equipment before starting this process	
Instructions		Illustrations

<p>1. Select material as per dummy</p>	
<p>2. Adjust feeder setting as per paper size</p>	
<p>3. Adjust pile setting as per paper size</p>	
<p>4. Adjust transfer roller and belt setting</p>	 
<p>5. Adjust folding grill & knife setting as per folding marks</p>	

Activity: 2/2

Carry out Folding Operation		
Module: 2	Learning Unit: 2	Make ready workstation for folding operation
	Practical Description:	Perform delivery trolley setting as per final folded sheet and take a test run
Time:	12 hours	
Equipment	Lifter, Stacker, Folding machine, Pallets	
Tools	Knife cutter, Allen key set, Screw Driver set, Spanner set, Grip Plier	
PPE	Safety shoes, helmet, Cover haul	
Materials	Cleaning Cloth, Paper, Nylon rope	
Key Point	<ul style="list-style-type: none"> • Counter setting • Delivery trolley setting • Verification of product as per dummy 	
Learning Outcome:	<ul style="list-style-type: none"> • Adjust delivery trolley as per instruction. • Adjust counter setting as per instruction. • perform test run 	
Precautions:	Ensure to wear safety shoes and other safety equipment before starting this process	
Instructions		Illustrations
1. Perform test run at folding machine		

<p>2. Adjust delivery trolley's side lay</p>	
<p>3. Verify counter at zero before test run</p>	
<p>4. Check the counter in production process</p>	
<p>5. Perform Test run</p>	

Learning Unit-3 - : Perform Folding machine operation

Overview: After successful completion of this learning module, the student will be competent to perform to perform folding machine operation.

This learning unit, the student will be competent to perform folding machine operation; numerical skills are underpinning knowledge and skills for the Competency Standard.

Describe the types of folding

Book folding is the stage of the book production process in which the pages of the book are folded after printing and before binding. Until the middle of the 19th century, book folding was done by hand, and was a trade.

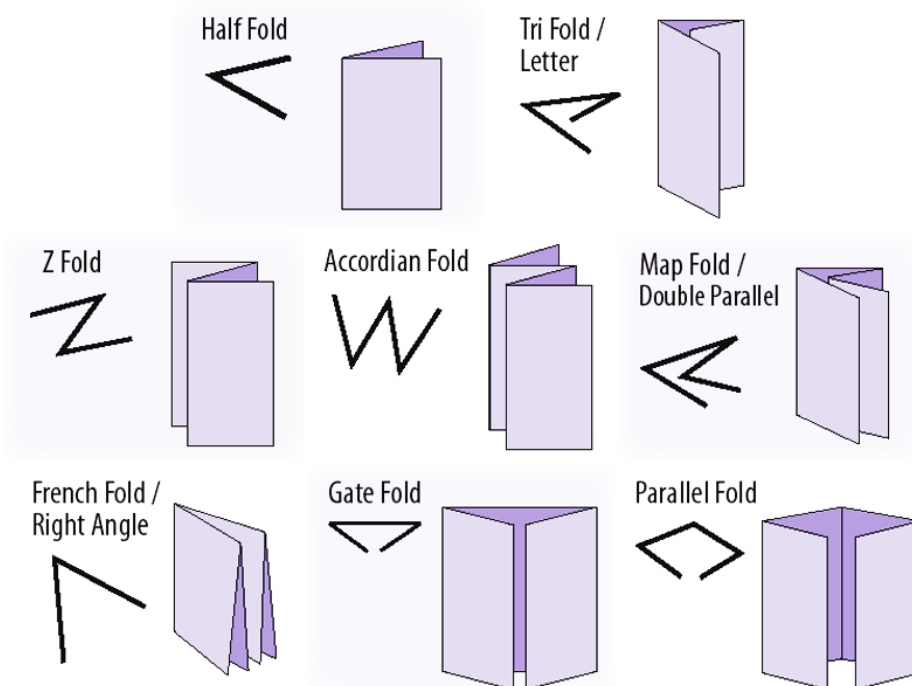

A "book fold" refers to how paper is folded so that pages can be turned. Some programs allow you to easily format your documents to print, so that they will be in the order of a booklet. Depending on the information you want to publish in your booklet, you can format it so that a document is split into two halves or four quarters.



Understand the procedure of folding operation

- Adjust paper size on feeder as per substrate.
- Pile up paper into the feeder.
- Adjust feeder setting as per substrate
- Adjust transfer rollers as per instruction
- Adjust folding grill as per folding mark
- Adjust folding knife on folding mark as per instruction.
- Adjust transfer belt as per substrate.
- Adjust delivery trolley as per instruction.
- Adjust counter setting as per instruction.
- Perform test run

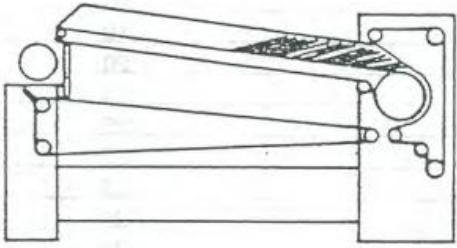
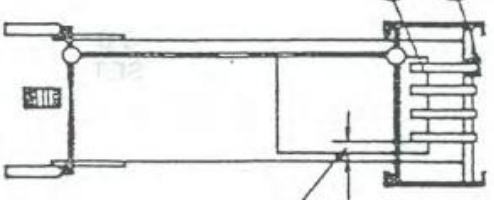
		Carry out Folding Operation	
Module: 2	Learning Unit: 3	Perform Folding machine operation	
	Practical Description:	Perform Folding machine operation	
Time:	140 hours		
Equipment	Lifter, Folding machine, Pallets		
Tools	Knife cutter, Allen key set, Screw Driver set, Spanner set, Grip Plier		
PPE	Safety shoes, helmet, Cover haul		
Materials	Cleaning Cloth, Paper, Nylon rope, Cleaning solvent		
Key Point	<ul style="list-style-type: none"> Describe the sizes of folding Understand the procedure of folding operation 		
Learning Outcome:	<ul style="list-style-type: none"> Get approval of folded form from the supervisor. Carry out folding machine operation as per instruction Check & maintain the quality of folding machine operation. Tie up the bundles as per instruction 		
Precautions:	Ensure to wear safety shoes and other safety equipment before starting this process		
Instructions		Illustrations	
1. Check all functions of the folding machine			

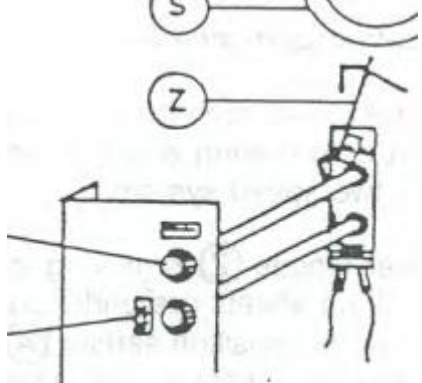
<p>2. Loading of feeder and setting of side lay</p>	
<p>3. Guide tapes adjustment</p>	
<p>4. Sheet loading</p>	
<p>5. Set sheet feeding control</p>	
<p>6. Adjustment of sheet curling (Feeler tongue)</p>	

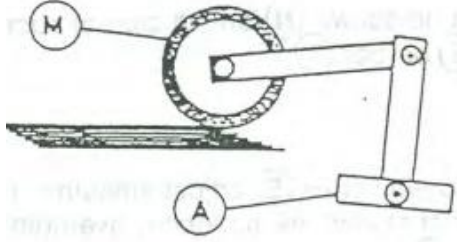
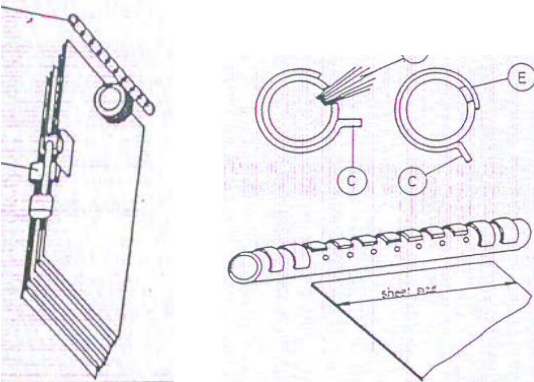
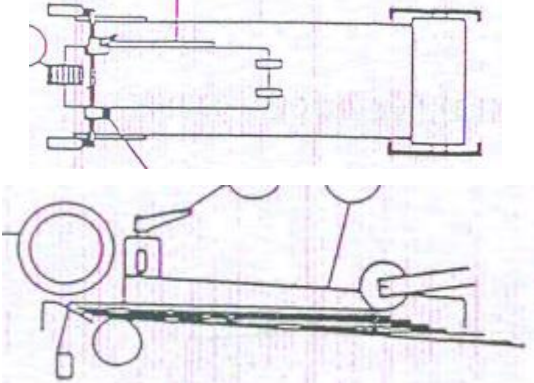
<p>7. Adjust back wheel (tail drag) as per sheet GSM</p>	 <p>The diagram shows a mechanical assembly with a large circular wheel on the left. A horizontal shaft extends from the center of the wheel to the right, where it is connected to a vertical support structure. A label 'M' points to the wheel, and a label 'A' points to the vertical support structure.</p>
<p>8. Adjust air sucking nozzle (Air blast)</p>	 <p>The diagram illustrates an air sucking nozzle mechanism. On the left, a vertical assembly is shown with a nozzle at the top. On the right, a detailed view shows two circular components, each labeled 'C', with a central nozzle. A label 'E' points to a component on the right. Below this, a horizontal cylindrical component with a series of small holes is shown, with a label 'sheet size' pointing to a triangular shape below it.</p>
<p>9. Adjustment of sheet guide</p>	 <p>The diagram shows a sheet guide mechanism. The top part is a side view of a horizontal assembly with a vertical guide on the right. The bottom part is a top-down view of the same assembly, showing a circular component on the left and a horizontal guide on the right.</p>

Learning Unit-4 - : Perform post production activity

Overview: After successful completion of this learning module, the student will be competent to Perform post production activity.

This learning unit, the student will be competent to Perform post production activity; numerical skills are underpinning knowledge and skills for the Competency Standard.

Describe the importance of maintaining/cleaning of work station

The importance of a clean workplace

The workplace environment influences employees' productivity, performance and well-being. No matter the industry, maintaining a clean workplace may help keep staff members safe, healthy and efficient. However, busy production schedules and increasing workloads may cause standards to dip.

While it may be tempting to put off dusting or other types of cleaning around the office or worksite, doing so may put employees at risk of suffering an injury or illness and may even impact performance levels. Maintaining a clean workplace is vital for employers to reduce their workers compensation claims and keep efficiency high.

Essential to safety

When employees work in a messy environment, they may not notice all hazards, which increases the risk of an accident. According to the Occupational Safety and Health Administration (OSHA), an occupational hazard is anything in the workplace that may cause harm. An occupational hazard is commonly caused by neglect on the part of the employer or a lack of awareness by workers. When the office or worksite isn't clean, it may increase the chance that a hazard will go unnoticed by a supervisor and staff members.

For example, if equipment is placed along an emergency route, workers may become injured if they trip or fall over it because it is out of place. If boxes aren't stacked properly, they may fall on a worker and cause an injury. Employers may want to remember to keep the workplace free of debris and remind workers to put all equipment, such as personal protective equipment (PPE), in designated places to prevent an accident.

Crucial to health



Flu season is rapidly approaching and workplaces may see an increase in the number of employees using sick days if they become ill. According to Kimberly-Clark Professional, germs can spread quickly through the workplace if supervisors and employees don't adequately sanitize their hands and their workspaces. Commonly used spaces, such as break rooms, can be hot spots for germs to accumulate.

According to Kimberly-Clark, break rooms have been found to have approximately 20,951 germs per square inch. Parts of the break room that tend to be touched the most, such as doorknobs, microwave oven handles and sinks, can be ripe with germs. Employers may want to clean these places on a frequent basis, and daily during flu season.

Another common health hazard of unclean workplaces is the germination of mold. According to OSHA, mold can cause adverse health effects for employees who are exposed to mold spores. Mold is a fungi that can release millions of spores into the air and can cause respiratory illnesses. Because of this, OSHA has strict standards employers are asked to follow to prevent the growth of mold in the workplace. According to OSHA, mold germination occurs in warm and humid conditions, making it essential that employers regularly clean worksite facilities, such as bathrooms, to reduce the chance of mold growth. Employers also may want to replace or clean indoor air filtration systems frequently to ensure any mold spores that are released into the air don't reach workers.

As a result, a messy or unhygienic workplace may influence worker productivity. If employees receive an injury or illness at work, they may not be able to perform their tasks as well as when they were healthy. This decrease in efficiency may cause deadlines to be missed and additional errors to occur.

Printing process includes a lot of steps and every step has its own importance. There are a lot of activities even before the printing like Design, Pre-press and after the actual printing is over, like cutting, folding, assembling and binding. But it is not always necessary that all printed items are subjected to these processes. For example, advertising pamphlets does not require binding.

		Carry out Folding Operation	
Module: 2	Learning Unit: 4	Perform post production activity	
	Practical Description:	Work area and machine cleaning	
Time:	14 hours		
Equipment	N/A		
Tools	Knife cutter, Allen key set, Screw Driver set, Spanner set, Grip Plier		
PPE	Safety shoes, helmet, Cover haul, cotton gloves		
Materials	Cleaning Cloth, Paper, Nylon rope, Cleaning solvent		
Key Point	<ul style="list-style-type: none"> • Check floor clean and tidy • Needle check 		
Learning Outcome:	<ul style="list-style-type: none"> • Remove the waste material as per instruction • Clean the work station as per instruction • Record the final counter along-with the wastages • Record downtime during folding machine operation 		
Precautions:	Ensure to wear safety shoes and other safety equipment before starting this process		
Instructions		Illustrations	
Perform cleaning of the machine			
Perform cleaning of the working area			

A good production log is like a training manual, helping the process of CI (Continuous Improvement). New staff can refer to the log, when trying to solve production problems.

A production log can be 'added to', continually leading to improvements in the manufacturing process and efficiency.

If a company is apply for a British Standards Certification, the log will be important evidence.

A production log allows the manufacturer to record problems and their solutions, which lead to a safer and more profitable production line.

		Carry out Folding Operation	
Module: 2	Learning Unit: 5	Maintain log Book	
	Practical Description:	Verify log book as per job	
Time:	06 hours		
Equipment	N/A		
Tools	Calculator, Measurement tape		
PPE	Safety shoes, Cover haul		
Materials	Note pad, Pen		
Key Point	<ul style="list-style-type: none"> Printed form sequence Paper handling 		
Learning Outcome:	<ul style="list-style-type: none"> Record the final counter along-with the wastages Record downtime during folding machine operation 		
Precautions:	Ensure to wear safety shoes and other safety equipment before starting this process		
Instructions		Illustrations	
1) Note daily production as per SOP			
2) Note daily rejection as per SOP			

Summary of the Module:

There are many variations in carryout folding operation module. This short guide will help you decide upon the right machine. When you narrow it down for your jobs, it also give you the below mentioned competences.

- Adjust paper size on feeder as per substrate.
- Pile up paper into the feeder.
- Adjust feeder setting as per substrate
- Adjust transfer rollers as per instruction
- Adjust folding grill as per folding mark
- Adjust folding knife on folding mark as per instruction.
- Adjust transfer belt as per substrate.
- Adjust delivery trolley as per instruction.
- Adjust counter setting as per instruction.
- Perform test run

Frequently Asked Questions (FAQs)

Question	Answer
1. Which quality key points to be consider in folding operation?	Check of proper folding is done on marking
2. Why we maintain log book?	To check and ensure the daily productivity
3. What is the purpose of feeder in folding machine?	To feed the paper
4. Why sheet counting is necessary?	To check the product quality To ensure the complete papers are recorded in log book
5. What purposes of fanning?	a) To remove static between sheets. b) Easy to count. c) To avoid doubling during number stamping. d) For proper stacking. e) To control the wastage.
6. Name the types of numbering	a) Numeric numbering. b) Roman numbering.
7. Which types of binding.is mostly used?	a) Saddle stitch binding. b) Hot glue binding. c) Hard cover binding

Self-Assessment

(MCQs)

Please mark the correct one from the given options. You can check your answer with the Answer Key at the end of this module

Q 1. Which purpose of fanning is right?

- a) To remove static between sheets.
- b) Easy to carry.
- c) To avoid numbering
- d) None of the above.

Q 2. Which type of numbering is right

- a. Numeric numbering.
- b. American numbering.
- c. Right numbering
- d. None of the above

Q 3. Name the type of folding in given picture.

- a) Panel Gate Fold.
- b) Double Gate Fold.
- c) Roll Fold.
- d) Double parallel Fold.

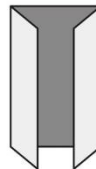

Q 4. Identify which type of binding is right.

- a. Stamp binding.
- b. Hot glue binding.
- c. Double binding
- d. Single binding

Q 5. It's necessary to check the number sequence in folding sample sheet.

- a) True.
- b) False.

- Q 6. What is the function of folding machine counter?
- a) To count the folded sheet
 - b) To count the number of stitch
 - c) To count the number of working hours.
 - d) To count the number of days
- Q 7. If fanning of paper not done properly does the paper run smoothly?
- a) True
 - b) False
- Q 8. Page sequence of folded sheet is same in saddle stitching and hot glue binding.
- a) True
 - b) False
- Q 9. Creasing pressure is adjusted according to.
- a) Substrate type
 - b) Press room moisture level
 - c) Artwork
 - d) Page sequence
- Q 10. Which of the following is a type of feeder in a folding machine?
- a) Vacuum feeder
 - b) Pressure feeder
 - c) Roller feeder
 - d) Ink feeder

Answer Key

MCQ No.	Correct Answer
1	A
2	A
3	A
4	B
5	A
6	A
7	B
8	B
9	A
10	A

POST PRESS OPERATIONS (Publishing)

Learner Guide

National Vocational
Certificate Level 3

Version 1 - December 2019

Module-3

Module 3: - Perform Thread Stitch Binding

Learning Unit:

After completion of this module the learner will be able to:

- LU1: Perform Substrate handling
- LU2: Make ready workstation for thread stitch binding operation
- LU3: Perform thread stitch binding operation
- LU4: Perform post production activity
- LU5: Maintain log Book.

Learning Unit-1 - : Perform Substrate handling

Overview: After successful completion of this learning module, the student will be competent to perform substrate handling.

This learning unit, the student will be competent to handle substrate; numerical skills are underpinning knowledge and skills for the Competency Standard.

Define Importance of the substrate stacking

In this unit below element is very essential.

Printed form sequence: It's very important factor in substrate handling, because this element is ensure your page gathering sequence.

- **Paper handling:** it's pre requisite process to perform stitching operation.

Method of checking substrate size:

- The paper size is mentioned on packing of paper ream for sheet-fed.
- The same can be verified through a full-size ruler by taking a sheet of paper from the ream and measuring it.

Substrate stitching procedure:



Stitching Machine

		Perform Thread Stitch Binding	
Module: 3	Learning Unit: 1	Perform Substrate handling	
	Practical Description:	Perform arrangement for stitching	
Time:	10 hours		
Equipment	Lifter		
Tools	N/A		
PPE	Safety shoes, helmet, Cover haul		
Materials	Cleaning Cloth, Cleaning brush		
Key Point	<ul style="list-style-type: none"> • Folding and gathering perfection • Number sequencing perfection 		
Learning Outcome:	<ul style="list-style-type: none"> • Verify binding side of book as per instruction. • Verify page number sequence of gathered book as per dummy. • Perform stacking of gathered book as per instruction. 		
Precautions:	Ensure to wear safety shoes and other safety equipment before starting this process		
Instructions		Illustrations	
1) Loading of folded format at machine conveyer			

2) Verify thread stitching and needle



3) Perform inspection of stitching in the end

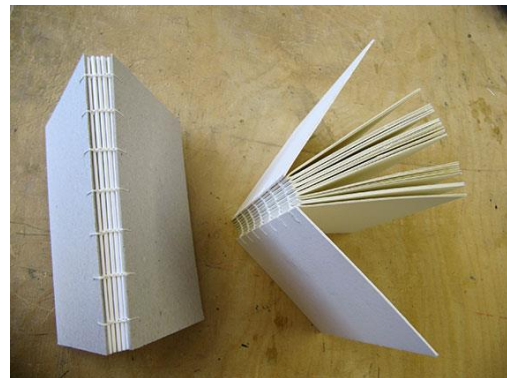

Learning Unit-2 - : Make ready workstation for thread stitch binding operation

Overview: After successful completion of this learning module, the student will be competent to make ready workstation for thread stitch binding operation.

This learning unit, the student will be competent to make ready workstation for thread stitch binding operation; numerical skills are underpinning knowledge and skills for the Competency Standard.

There is many styles of binding thread stitch is one of them. The different styles of bindings are listed below;

Binding Styles

- Spiral Wire **Binding**. The **book** is punched with a series of small holes on the left.
- Plastic Comb **Binding**.
- Saddle Stitch **Binding**.
- Loop Stitch **Binding**
- Side Stitched **Binding**.
- Sewn bound **Binding**
- Perfect bound **Binding**
- Tape bound **Binding**
- Screw bound **Binding**
- Hard cover bound **Binding**
- Case Bound (Section Sewing).
- Perfect **Binding**.
- Wire-O **Binding** or Double Wire **Binding**.
- Post **Binding**.

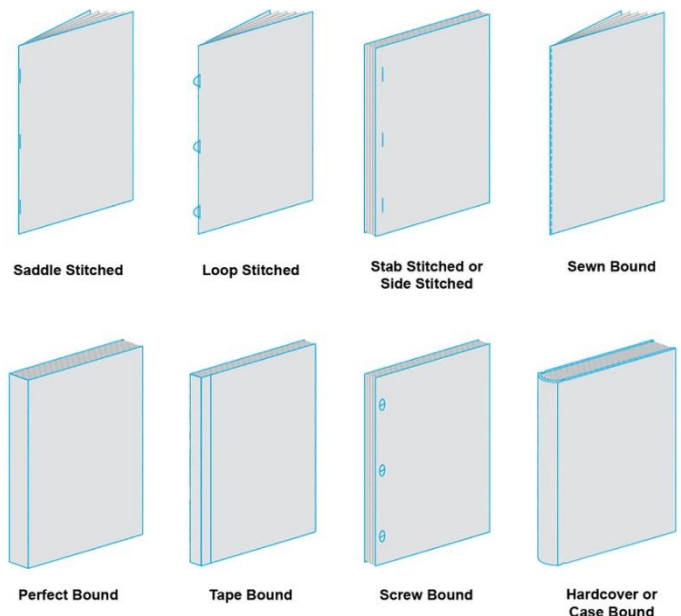

Describe the types of needle.

There are many types of needles available of **different lengths, different thickness, and different forms**. Which type should you use during bookbinding?

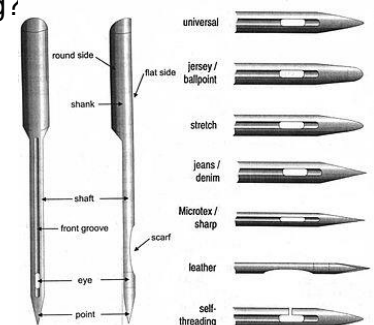

Regular Needles vs Curved Needles



Regular needles refer to the straight needles that are commonly used for sewing. These are easily available in most craft stores and even in departmental stores.



Curved Needles are commonly used in upholstery where thick fabric such as leather have to be sewn onto furniture. These needles are curved to allow users to reach odd angles.

Curved needles may not be as easily available as regular needles. They also tend to break easily due to their shape and the way you handle them.

We prefer to use curved needles as its shape provides an easier grip and allows us to work the needle around edges of the book with ease.

What to look out for when choosing needles for bookbinding?

Below are the basic features that we look at when selecting our bookbinding needles.

Other than looking at the main shape of the needle, I also look at the **end of the needle**.

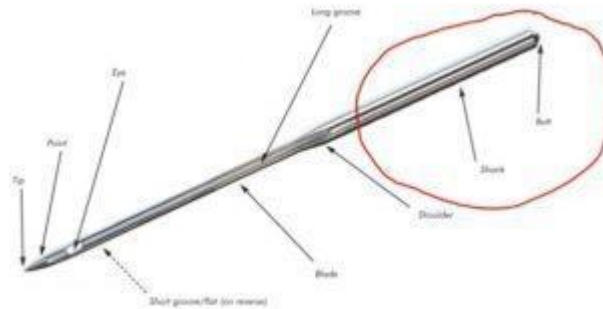

Generally, I would prefer needles with a **longer shank** (where you put the thread through) for *easy threading* and a **narrow butt** (the end of the needle) to *avoid the painful experience* of having to pull the last bit of the needle through the book signature.

2. Thickness of Needle

This would depend on the thickness of the thread you are using.

You will want a needle that is **slightly thicker than the thread that you are using** for ease of sewing. Also bear in mind that depending on the sewing/bookbinding method you use, you may need to thread through the same hole several times.

The thickness of the needle also suggests its durability. You will want to choose a needle that does not break easily.

*** Tip from a bookbinder: When buying an assorted set of needles, always make sure that there is more than 1 needle of every size. This will ensure that you have a backup available should your working needle break.*

3. Length of Needle

Generally, a shorter needle is easier to maneuver during the sewing of the book signature, especially at the tight corners and bends. However a short needle can be difficult to grip.

Describe the types and use of Thread.

Here are some common bookbinding thread options:

- Linen/Nylon **Thread**.
- Bleached/uncolored.
- Thickness: 30 – 35.
- Number of strands: 3 – 4 / Some **bookbinders** prefer 7 strands for exposed **stitches** for aesthetic purposes.
- Length: 50 yards (45.72m) / shorter options if you are getting colored **threads**.
- Waxed **Thread** for convenience.

There is no formula to select threads; instead these ten aspects need to be considered:

1. THICKNESS OF THREAD. Thick thread (or more plies) = more swell. Thin thread (or fewer plies) = less swell. Although not ideal, the thickness of thread can be changed during sewing if too much or too little swell develops.

2. HOW HARD OR SOFT THE THREAD IS. Hard thread does not flatten in the signatures = more swell. Soft thread flattens in the signatures = less swell. A compressible thread gives more control. It is often advisable to untwist hard modern threads a bit to make them softer by running them through your fingernail and thumb, and let them relax. Waxing thread also makes it harder, so I generally avoid it if possible. Sometimes excessive kinking and twisting comes from using too small of a needle. Softer thread can fray more during sewing, though.

3. THICKNESS OF THE TEXT PAPER. Thick paper absorbs more thread = less swell. Thin paper absorbs less thread = more swell.

4. HOW HARD OF SOFT THE PAPER IS. Soft paper absorbs more of the thread = less swell. Hard paper absorbs less thread = more swell. It is easier to control swell with softer paper. Guarding the spine will increase swell. Washing and resizing can also affect how much swell develops. Swell can also be adjusted before sewing by beating or otherwise compressing the sections.

5. HOW MANY LEAVES ARE IN EACH SIGNATURE? More leaves can absorb more thread = less swell. Fewer leaves = more swell.

6. HOW MANY SIGNATURES THERE ARE? More signatures = more swell. Fewer signatures = less swell. Some binders like to visualize this by wrapping the thread around a pencil the same number of times as there are signatures.

7. SEWING STYLE. All-along, two-on, three-on, etc. All-along produces the most swell, more “-on” sewing styles = less swell. Packed sewing produces more swell due to a small overlap of thread. This can be controlled, to produce naturally packed sewing, which has one length of thread on the cords for each signature.

8. SEWING SUPPORTS. Tapes, cords, thongs. Tapes produce the least swell, cords and thongs slightly more since the thread can overlap slightly inside the signature. Supports also differ in the amount of adjustment that can be done after sewing, ie. how

much the thread can move on the supports during consolidation and backing. A professional sewing frame, such as the Nokey makes this easier.

9. HOW MUCH CONSOLIDATION IS PERFORMED DURING SEWING? More consolidation during sewing= less swell. I have often observed students sewing identical text blocks, with identical thread, end up with significantly different results. A loaded stick, or knocking down stick can help with compression, although some people prefer to use a bone folder or wedge shaped piece of wood.

10. TIGHTNESS OF SEWING. Tighter sewing makes a thinner book before pressing. Looser sewing can develop due to improper tensioning or too large of a needle. A book sewn too tightly can develop a “banana” shape, thinner at the kettle stitch. Even tension is crucial.

Describe the importance of clamping

This machine is meant for stitching the books, booklets and currency notes. The machine gives higher rate of efficiency and accuracy at highest speed. It is distinguished in terms of simple mechanism and remarkable exterior presentation. The machine is most simple in terms of operation, clean formation of staples.



Perform Thread Stitch Binding	
Module: 3	Learning Unit: 2 Make ready workstation for thread stitch binding operation
	Practical Description: Perform pre maintenance
Time:	16 hours
Equipment	Stitching machine
Tools	Knife cutter, Allen key set, Screw Driver set, Spanner set, Grip Plier
PPE	Safety shoes, helmet, Cover haul
Materials	Cleaning Cloth, Paper, Nylon rope, Cleaning solvent
Key Point	<ul style="list-style-type: none"> • Material arrangement as per SOP • Folded format loading on conveyer
Learning Outcome:	<ul style="list-style-type: none"> • Adjust book clamping as per instruction • Adjust required needle as per instruction • Set required thread as per docket. • Adjust thread cutting as per instruction • Perform test run
Precautions:	Ensure to wear safety shoes and other safety equipment before starting this process
Instructions	Illustrations
1) Verify needle size as per thread thickness	

<p>2) Check and load thread spool</p>	
<p>3) Perform oiling before start of machine operation</p>	
<p>4) Perform cleaning before start of machine operation</p>	

Learning Unit-3 - : Perform thread stitch binding operation

Overview: After successful completion of this learning module, the student will be competent to Perform thread stitch binding operation.

This learning unit, the student will be competent to Perform thread stitch binding operation; numerical skills are underpinning knowledge and skills for the Competency Standard.

Understand the procedure thread stitch binding operation

- **Manual thread stitching procedure**



Take a piece of thread that is almost 30 inches in length; a smaller size can cause inconvenience. If your book is thick, you may need to use an additional piece of thread, which will be discussed in detail later. For right now, apply wax onto your thread with beeswax; pinch the thread against it at least two or three times as shown in figure. This makes it easier for you to sew the signatures, prevents the thread from knotting and increases its life. Once you have waxed, tie a knot at about three inches from one end of the thread.

At this stage, you would have already placed your signature on the platform with the marks and the tapes aligned. Open your signature a little bit at the center as shown in figure. Now pass the needle through the hole you made for the bottom kettle stitch until it reaches the open center. Hold the needle in your hand and pull the thread as shown in figure until there is no space between the knot and the signature edge on the outer side. Pass the needle through the hole near the bottom tape as depicted in figure, and pull the thread once again to tighten it. Let the thread pass onto the tape, and then insert the needle into the hole above the tape. This has been illustrated in figure. In this same manner, pass the thread in and out, sewing the signature along the folded edge. When you reach the top kettle stitch, bring the needle on the outside edge, and straighten out the thread such that it aligns with the signature's side as demonstrated in figure. Snug up the thread, but make sure that it does not become too tight.

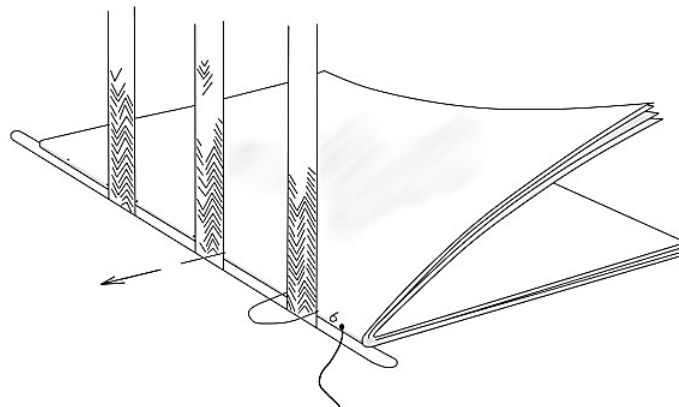
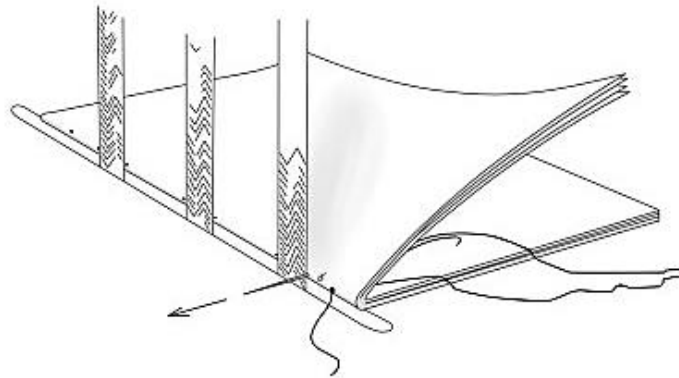
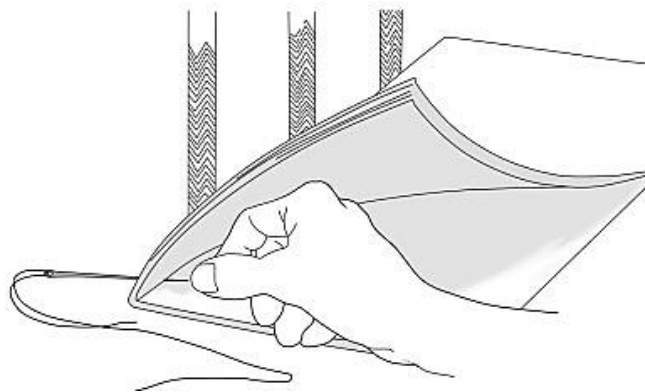
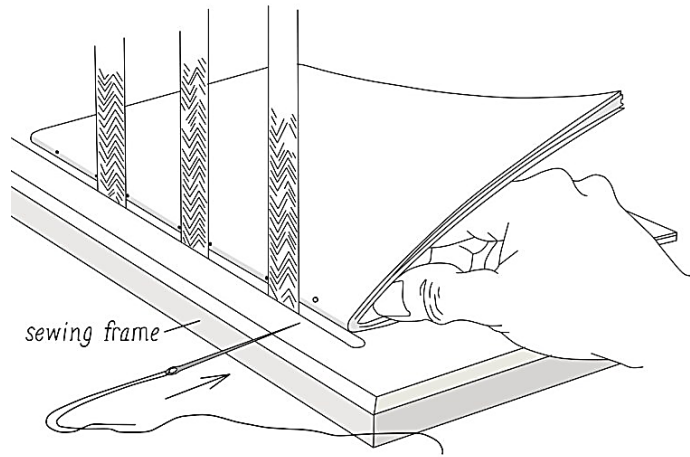

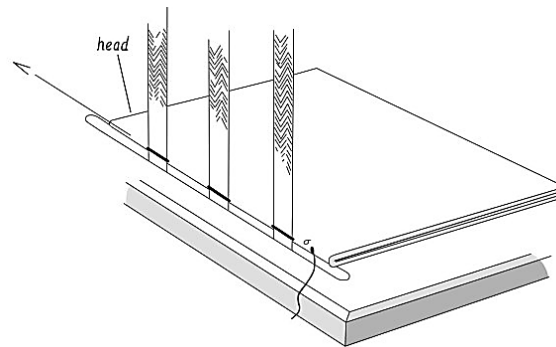

Now place another signature onto the one which you just sewed. Pass the needle through the top hole for the kettle stitch and in the manner described above, sew the signatures over the tape. Do this until you reach the bottom hole for the kettle stitch as shown in figure. Pull the thread, and once again make sure it is not too tight. If this happens, it would just tear apart the paper. Now tie up the two signatures at the top and bottom kettle stitches. Take the knotted end of the thread in your hand, and make a loop such that the thread goes around and below the knot. Pass the needle into this loop, and pull the thread until the stitch is tight. See figure.

Continue sewing the rest of the signatures with the same technique. Whenever you reach a kettle stitch, make sure to tie it together with the previous ones as demonstrated in figure. Ascertain that all the kettle stitches are firm and tight, but slightly flexible at the same time so that the book can easily be opened up later on as shown in figure. In case, the kettle stitches are too tight or bear a high amount of tension, the book would become misshaped from the back or the signatures would tear apart.

Splicing the Thread

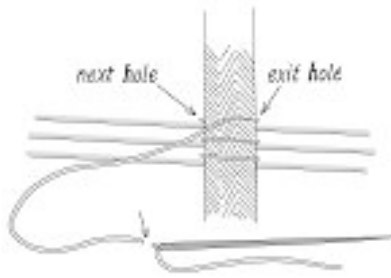

Cutting the Thread, Splicing the Thread during bookbinding

In the previous section, it was mentioned that the thread length should not be more than 30 inches long because that would make sewing difficult. But what if your book is a thick and bulky one, and you need to use more thread? If this is the case, splice a new piece of thread when only four to five inches of the previous thread are left. However, you would have to do this, when your needle is on the outer edge of the signature and not in the center portion.

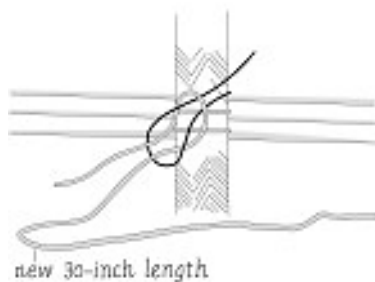

Tying up the end after stitching, square knot

Usually, when you insert your needle on the outside edge, you pass it onto the tape and into the next hole. However, this time, just cut the thread at the head of the needle as shown in figure. Now tie up the end of this thread to another piece that is also 30 inch long; secure the two pieces with a tight square knot that should be close to the hole from which you just brought the needle out as demonstrated in figure. If you knot the threads near the next hole, it would probably create an obstacle in sewing, and becoming jammed, would just loosen the work you have done so far.

Knotting up multiple threads during stitching

Before knotting up the threads, wax the new piece of thread. You can knot up the two pieces of thread in as similar manner with which you create a knot in a single thread piece. Knot up the previous thread, but before tightening it up, pass the new thread through the center of the knot. Take both of the loose ends in your hand and pull them to tighten the knot as illustrated in figure.

Knotting the Last Stitch



Tightening the Taps after Stitching the Signatures

When you sew the last signature onto the rest of them, you would have to create the final knot. Tie the last kettle stitch and then secure it with a double knot. Cut off the remaining thread piece except for a quarter inch of it. Remove the tapes from the crossbar, tightening them up by pulling them from both sides as demonstrated in figure. Stick the tapes onto the signature for additional support.



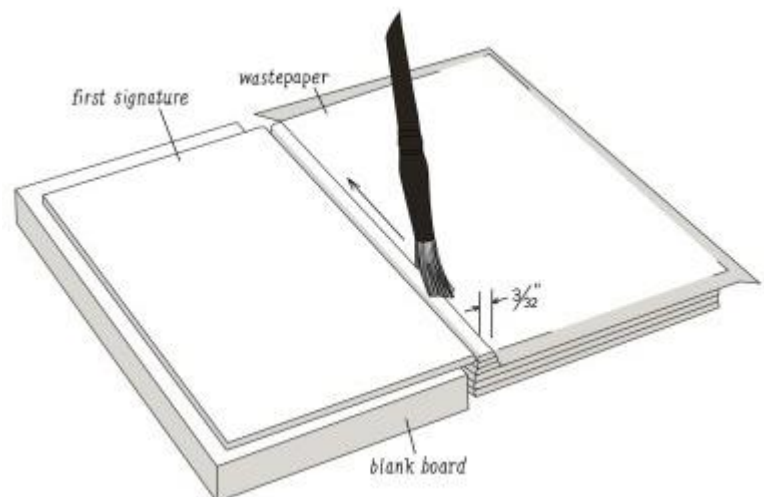
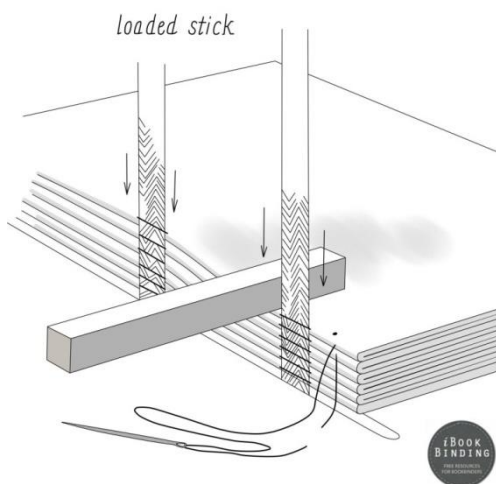

Handling the Bulge

If your book is heavy comprising of many signatures, it may swell up because of the threads that lie between the signatures. You can reduce this effect if you press every two or three signatures with a loaded stick while sewing them as depicted in figure 63. This would force the thread into the paper and would make the folds more compact. You can decrease the swelling even more if you tie the threads together over the center tape as shown in figure. Pass the needle carefully beneath the thread and tie up each group separately. You can tie together three to four groups as well, but do not increase them beyond this because it would misshapen the back of the book, tear apart or weaken the paper.

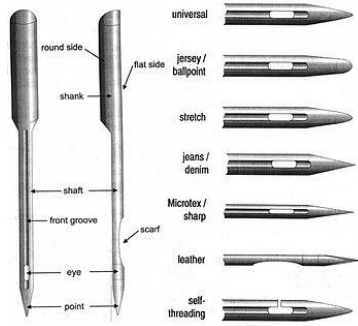

Activity: 1/1.

Module: 3	Perform Thread Stitch Binding	
	Learning Unit: 3	Perform thread stitch binding operation
	Practical Description:	Operate thread stitching machine
Time:	40 hours	
Equipment	Stitching machine	
Tools	Knife cutter, Allen key set, Screw Driver set, Spanner set, Grip Plier	
PPE	Safety shoes, helmet, Cover haul	
Materials	Cleaning Cloth, Paper, Nylon rope, Cleaning solvent	
Key Point	<ul style="list-style-type: none"> • Machine make ready • Thread thickness according to folded format 	
Learning Outcome:	<ul style="list-style-type: none"> • Get approval from the supervisor. • Carry out thread stitch binding machine operation as per instruction • Check & maintain the quality of thread stitch binding machine operation. 	
Precautions:	Ensure to wear safety shoes and other safety equipment before starting this process	
Instructions		Illustrations
1) Arrangement of folded format		

<p>2) Perform Needle check</p>	 <p>The diagram shows two views of a needle: a side view with labels 'round side', 'shank', 'shaft', 'front groove', 'eye', and 'point'; and a front view with labels 'flat side' and 'scarf'. To the right, six different needle types are shown: universal, jersey / ballpoint, stretch, jeans / denim, Microtex / sharp, and leather. At the bottom, a self-threading needle is also depicted.</p>
<p>3) Perform Thread check</p>	 <p>A photograph showing a sewing machine with several spools of white and yellow thread mounted on the top. The machine is in a factory or workshop setting.</p>
<p>4) Loading of folded format on machine conveyor</p>	 <p>A photograph of a sewing machine conveyor belt. Several pieces of white fabric are being fed into the machine. The machine is a large industrial-style sewing machine.</p>
<p>5) Check quality as per SOP</p>	 <p>A line drawing of a finished book or binder. The pages are stacked and bound together. The cover is visible on the right side.</p>

Learning Unit-4 - : Perform post production activity

Overview:

After successful completion of this learning module, the student will be competent to Perform post production activity.

This learning unit, the student will be competent to Perform post production activity; numerical skills are underpinning knowledge and skills for the Competency Standard.

Describe the importance of maintaining/cleaning of work station.

The importance of a clean workplace

The workplace environment influences employees' productivity, performance and well-being. No matter the industry, maintaining a clean workplace may help keep staff members safe, healthy and efficient. However, busy production schedules and increasing workloads may cause standards to dip.

While it may be tempting to put off dusting or other types of cleaning around the office or worksite, doing so may put employees at risk of suffering an injury or illness and may even impact performance levels. Maintaining a clean workplace is vital for employers to reduce their workers compensation claims and keep efficiency high.

Essential to safety

When employees work in a messy environment, they may not notice all hazards, which increases the risk of an accident. According to the Occupational Safety and Health Administration (OSHA), an occupational hazard is anything in the workplace that may cause harm. An occupational hazard is commonly caused by neglect on the part of the employer or a lack of awareness by workers. When the office or worksite isn't clean, it may increase the chance that a hazard will go unnoticed by a supervisor and staff members.

For example, if equipment is placed along an emergency route, workers may become injured if they trip or fall over it because it is out of place. If boxes aren't stacked properly, they may fall on a worker and cause an injury. Employers may want to remember to keep the workplace free of debris and remind workers to put all equipment, such as personal protective equipment (PPE), in designated places to prevent an accident.

Crucial to health



Flu season is rapidly approaching and workplaces may see an increase in the number of employees using sick days if they become ill. According to Kimberly-Clark Professional, germs can spread quickly through the workplace if supervisors and employees don't adequately sanitize their hands and their workspaces. Commonly used spaces, such as break rooms, can be hot spots for germs to accumulate.

According to Kimberly-Clark, break rooms have been found to have approximately 20,951 germs per square inch. Parts of the break room that tend to be touched the most, such as doorknobs, microwave oven handles and sinks, can be ripe with germs. Employers may want to clean these places on a frequent basis, and daily during flu season.

Another common health hazard of unclean workplaces is the germination of mold. According to OSHA, mold can cause adverse health effects for employees who are exposed to mold spores. Mold is a fungi that can release millions of spores into the air and can cause respiratory illnesses. Because of this, OSHA has strict standards employers are asked to follow to prevent the growth of mold in the workplace. According to OSHA, mold germination occurs in warm and humid conditions, making it essential that employers regularly clean worksite facilities, such as bathrooms, to reduce the chance of mold growth. Employers also may want to replace or clean indoor air filtration systems frequently to ensure any mold spores that are released into the air don't reach workers.

As a result, a messy or unhygienic workplace may influence worker productivity. If employees receive an injury or illness at work, they may not be able to perform their tasks as well as when they were healthy. This decrease in efficiency may cause deadlines to be missed and additional errors to occur.

Activity 1/1:

Perform Thread Stitch Binding		
Module: 3	Learning Unit: 4	Perform post production activity
	Practical Description:	Work area and machine cleaning
Time:	08 hours	
Equipment	N/A	
Tools	Knife cutter, Allen key set, Screw Driver set, Spanner set, Grip Plier	
PPE	Safety shoes, helmet, Cover haul, cotton gloves	
Materials	Cleaning Cloth, Paper, Nylon rope, Cleaning solvent	
Key Point	<ul style="list-style-type: none"> • Check floor clean and tidy • Needle check 	
Learning Outcome:	<ul style="list-style-type: none"> • Remove the waste material as per instruction • Clean the work station as per instruction 	
Precautions:	Ensure to wear safety shoes and other safety equipment before starting this process	
Instructions		Illustrations
1) Perform cleaning of the machine		
2) Perform cleaning of the working area		

A good production log is like a training manual, helping the process of CI (Continuous Improvement). New staff can refer to the log, when trying to solve production problems.

A production log can be 'added to', continually leading to improvements in the manufacturing process and efficiency.

If a company is apply for a British Standards Certification, the log will be important evidence.

A production log allows the manufacturer to record problems and their solutions, which lead to a safer and more profitable production line.

		Perform Thread Stitch Binding	
Module: 3	Learning Unit: 5	Maintain log Book	
	Practical Description:	Verify log book as per job	
Time:	06 hours		
Equipment	N/A		
Tools	Calculator, Measurement tape		
PPE	Safety shoes, Cover haul		
Materials	Note pad, Pen		
Key Point	<ul style="list-style-type: none"> • Printed form sequence • Paper handling 		
Learning Outcome:	<ul style="list-style-type: none"> • Record the final counter along-with the wastages • Record downtime during folding machine operation 		
Precautions:	Ensure to wear safety shoes and other safety equipment before starting this process		
Instructions		Illustrations	
1) Note daily production as per SOP			
2) Note daily rejection as per SOP			

Summary of the Module:

There are many variations to Perform Thread Stitch Binding module. This short guide will help you decide upon the right machine. When you narrow it down for your jobs, it also give you the below mentioned competences.

- Verify binding side of book.
- Verify page number sequence of gathered book.
- Adjust book clamping.
- Adjust and select required needle
- Set required thread.
- Adjust thread cutting
- Carry out thread stitch binding machine operation
- Check & maintain the quality of thread stitch binding machine operation.
- Work station cleaning and safety controls.
- Log book maintaining.

Frequently Asked Questions (FAQs)

Question	Answer
1. Enlist two types of threads.	a) Cotton thread b) Synthetic thread.
2. What consumable is used in thread binding?	a) Thread b) Needle
3. How to carry out thread stitching?	Carry out thread stitch binding operation as per instruction
4. How to verify binding side?	Verify binding side of book as per instruction.
5. Why we maintain log book?	To check and ensure the daily productivity
6. What is the rule to verify page number sequence?	Verify page number sequence of gathered book as per dummy.

Self-Assessment (MCQs)

- Q 1. Needle size depends on paper thickness and number of pages.
- a) True
 - b) False
- Q 2. Which type of thread used in stitching?
- a. Paper thread
 - b. Cotton thread
 - c. BS thread
 - d. American thread
- Q 3. Forms measurement is necessary in thread stitch binding operation.
- a) True
 - b) False
- Q 4. Thread stitch binding has more strength then hot glue binding.
- a) True
 - b) False
- Q 5. In thread stitch binding operation there is no need to clamp the forms.
- a) True
 - b) False
- Q 6. On what part of the book, thread stitching operations is performed.
- a) Foot
 - b) Head
 - c) Spine
 - d) Side

- Q 7. Form gathering sequence of thread stitched binding is the same as.
- a) Hot glue binding
 - b) Spiral binding
 - c) Loose pages
 - d) None of the above
- Q 8. Can we use saddle stitched wire in thread binding?
- a) No
 - b) Yes
- Q 9. After stitching books are separated by:
- a) Size
 - b) By number sequence
 - c) Color
 - d) Cutting of thread
- Q 10. What consumable is used in thread binding?
- a. Thread
 - b. Ink
 - c. Water
 - d. Glue

Answer Key

MCQ No.	Correct Answer
1	A
2	B
3	A
4	A
5	B
6	C
7	A
8	A
9	D
10	A

POST PRESS OPERATIONS (Publishing)

Learner Guide

National Vocational
Certificate Level 3

Version 1 - December 2019

Module-4

Module 4: - Perform Waste Management

Learning Outcomes:

After completion of this module the learner will be able to:

LU1: Manage Post press waste

LU2: Handle toxic chemicals Handle

LU3: Non-toxic chemicals

LU4: Manage solid waste

Learning Unit - :

LU 1: Manage Post press waste

Overview: This learning unit describes the types of post press waste and safety precautions which have to be in consideration to manage printing waste. It also defines the methods of printing press waste control.

Printing press waste:

It is important to note that waste differ from process to process and the methods of reducing waste in one printing process do not necessarily apply to other printing processes.

There are three major waste streams found in the printing industry:

- i. **Solid waste** – in general printing environment solid waste could consist of the following: empty containers, used film packages, outdated materials, damaged plates, developed films, test production, bad printing or spoilage, damaged product, and scrap paper
- ii. **Water waste** – water waste from printing operations may contain lubricating oils, waste ink, clean-up solvents, photographic chemicals, acids, alkaline, and plate coatings

Air emissions – some printing operations produce volatile organic compound emissions from the use of cleaning solvents and inks, as well as alcohol and other wetting agents used in printing.



Safety precautions to manage printing waste:

Printing industry can use a variety of ways to reduce the amount of waste they generate while increasing their operational efficiency. Best management practices create the most cost-effective way to decrease the amount of waste generated from operations. This includes a careful control of raw materials, practical scheduling, and job management.

Another potential hazardous waste reduction technique for printing presses, requires good housekeeping. Good housekeeping measures can greatly decrease the amount of waste that a press generates.

To reduce excess waste production, printing presses should:

(a) Make sure container lids are tight fitting whenever they are not in use to prevent loss of chemical through evaporation or spoilage. Keeping lids on containers also prevents contamination with water, dirt, or other materials

(b) Use spigots and pumps when dispensing new materials and funnels when transferring waste to storage containers to reduce the possibility of spills

(c) Store products in locations that will preserve their shelf life. For instance, solvents should be kept in locations protected from extreme temperatures

(d) Never mix different types of waste together. Mixing wastes may make recycling impossible or make waste disposal more expensive

(e) Keep printing floor clean and orderly to prevent accidents and spills.

Methods of printing press waste control:

Waste avoidance generally delivers the best financial and environmental outcomes. The waste management provides a framework for managing waste: avoid; reduce; reuse; recycle; and dispose.

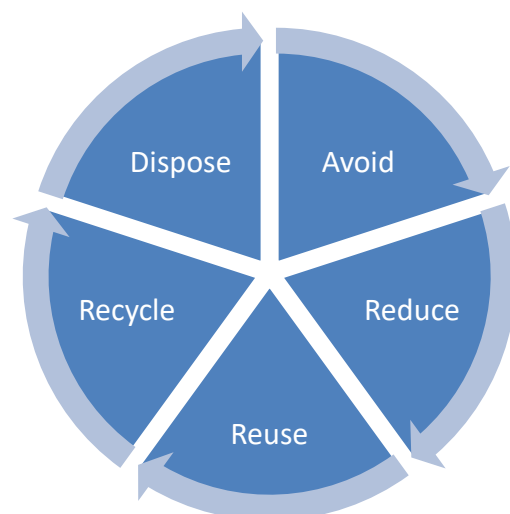

Following are various methods to reduce waste in print presses:

1. Management Commitment

An important aspect of any waste reduction program is management commitment. Commitment shows employees that managers place a high priority on waste reduction.

2. Employee Awareness

Hazardous waste reduction efforts should be emphasized to each employee, from the general manager to machine operators.

3. Good Housekeeping

Good housekeeping comprises of:

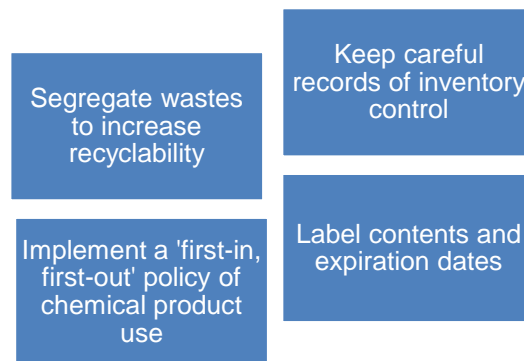

Waste Reduction Alternatives for Inks

- Fill ink duct only enough for a single run or shift
- Run similar jobs simultaneously to reduce waste generation between cleanup and start of the next run
- Use water-based inks whenever possible to cut down on the use of solvent based inks that cause employee and environmental hazards
- Clean ink fountains only when changing colors or when the ink might dry out between runs to reduce waste ink generation

4. Solvent Alternatives





- Use soap or detergent solutions wherever possible
- Use solvents only for cleaning inks and oils
- Minimize spills and use dry methods for cleanup wherever possible

5. Substrate waste reduction

- Optimize substrate size to minimize excess trim
- Manage stock and ordering to minimize waste
- Use the blank side of used papers for press set up instead of new sheets

Practical Activity 1/1:

		Perform Waste Management	
Module: 4	Learning Unit: 1	Manage Post press waste	
	Practical Description:	Sort and maintain the waste generated at the workplace according to usability with maintaining its record.	
Time:	06 hours		
Equipment	Folding machine		
Tools	N/A		
PPE	Uniform, Safety shoes, Gloves		
Materials	Waste bin or containers		
Key Point	Gathering basic knowledge for sorting waste material at workplace and maintain its record keeping.		
Learning Outcome:	<ul style="list-style-type: none"> • Sort the waste generated at the workplace according to usability • Tag the reusable components/item of the waste • Maintain record of reusable components of the waste • Reduce the waste generation in routine work by reuse the categorized waste as per requirement. • Handle hazardous waste as per instruction. 		
Precautions:	Sort & Handle the waste material carefully		
Instructions		Illustrations	
1. Collect all the waste generated at workplace.			

<p>2. Sort out unusable articles</p>	
<p>3. Place unusable articles at appropriate place and label it.</p>	
<p>4. Dispose of waste in a proper way.</p>	
<p>5. Record all reusable waste articles in a register</p>	

Learning Unit - :

LU 2: Handle toxic chemicals

Overview: This learning unit defines about the different types of toxic materials, and their respective management techniques.

Toxic chemical:

A toxic substance is a substance that can be poisonous or harmful on human contact. Products that we use daily, such as cleaners, alcohol, oil can also be toxic. Any chemical can be toxic or harmful under certain conditions.

Potentially harmful chemicals used in Printing:

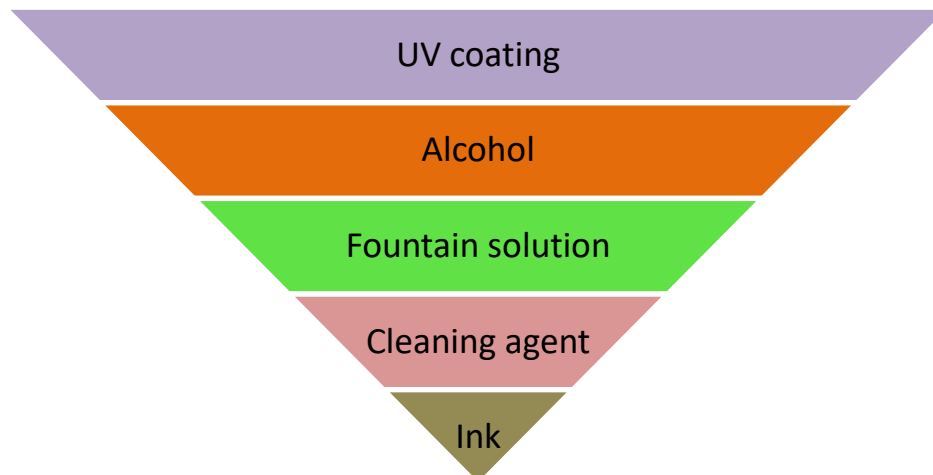

Procedure of toxic chemical management:





Here are some ground rules that can be useful to have while at work to ensure safe handling of toxic chemicals:

- Follow all established procedures and perform job duties as per training.
- Be cautious and plan ahead. Think about what could go wrong and pay close attention to what you're doing while you work.
- Always use required PPE (Personal Protective Equipment) and inspect them carefully before each use to make sure it's safe to use. Replace worn out or damage PPE; it won't provide adequate protection.
- Make sure all containers are properly labeled and that the materials are contained in an appropriate container. Report any damaged containers or illegible labels to your supervisor.

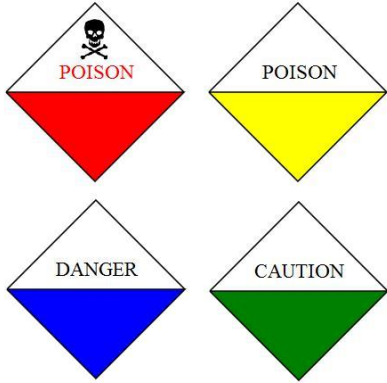
- Read labels and the material safety data sheet (MSDS) before using any material to make sure you understand hazards and precautions.
- Use all materials solely for their intended purpose. Don't, for example, use solvents to clean your hands, or gasoline to wipe down equipment.
- Never eat or drink while handling any materials, and if your hands are contaminated.
- Keep yourself and your work area clean. After handling any material, wash your hands thoroughly with soap and water. Clean work surfaces at least once a shift so that contamination risks are minimized.
- Learn about emergency procedures and equipment. Understanding emergency procedures means knowing evacuation procedures, emergency reporting procedures, and procedures for dealing with fires and spills. It also means knowing what to do in a medical emergency if a co-worker is injured or overcome by chemicals.
- Learn the appropriate use of safety equipment provided. For example; which fire extinguisher is used for which class of fire?

Type Extinguisher	Fire		CLASS A	CLASS B	CLASS C	CLASS D	Electrical	CLASS F	Comments
	Combustible materials (e.g. paper & wood)	Flammable liquids (e.g. paint & petrol)	Flammable gases (e.g. butane and methane)	Flammable metals (e.g. lithium & potassium)	Electrical equipment (e.g. computers & generators)	Deep fat fryers (e.g. chip pans)			
Water	✓	✗	✗	✗	✗	✗	✗	✗	Do not use on liquid or electric fires
Foam	✓	✓	✗	✗	✗	✗	✗	✗	Not suited to domestic use
Dry Powder	✓	✓	✓	✓	✓	✓	✗	✗	Can be used safely up to 1000 volts
CO2	✗	✓	✗	✗	✗	✓	✗	✗	Safe on both high and low voltage
Wet Chemical	✓	✗	✗	✗	✗	✗	✗	✓	Use on extremely high temperatures

Perform Waste Management		
Module: 4	Learning Unit: 2	Handle toxic chemicals
	Practical Description:	Tagging and storing of toxic waste chemical containers at designated place
Time:	06 hours	
Equipment	Folding machine	
Tools	N/A	
PPE	Uniform, Safety shoes, mask, Gloves	
Materials	Toxic Chemical waste containers	
Key Point	Keep tagging, storing and handling of toxic material carefully.	
Learning Outcome:	<ul style="list-style-type: none"> • Tag containers of toxic chemical as per instruction. • Store toxic waste at designated place. • Manage Inflammable toxic chemical waste as per instruction. • Manage non- inflammable toxic chemical waste as per instruction. 	
Precautions:	Ensure the safety	
Instructions		Illustrations
1. Prepare tags for waste chemicals.		

<p>2. Place containers of toxic waste at a safe place carefully.</p>	
<p>3. Tag the toxic containers accordingly</p>	
<p>4. Store the toxic waste at its proper place.</p>	
<p>5. Prepare tags for all inflammable and non-inflammable toxic waste chemicals.</p>	

6. Place containers of inflammable and non-inflammable toxic waste at a safe place carefully.



7. Tag the inflammable and non-inflammable toxic waste containers according.



8. Store the inflammable and non-inflammable toxic waste at its proper place accordingly.



9. Dispose-off all waste as per SOPs of press room.



10. Wash hands thoroughly



Learning Unit - :

LU 3: Handle non-toxic chemicals

Overview: This learning unit defines about the different types of non-toxic chemicals, and procedure of their waste disposal.

Remember:

"Hazardous" includes flammable liquids even if water soluble

Non-toxic chemicals:

Nontoxic materials are not considered to be harmful to human health. The toxicity must be evaluated in terms of quantity of material. If the quantity of a substance that causes harm is less, its toxicity is determined to be higher.

Similarly, there is a minimum dose for nearly all substances below which toxic effects are not seen, called the toxicity endpoint. Toxic waste poisons the groundwater or makes nearby animals sick, but nontoxic waste tends to break down without any negative consequences.

Non-toxic materials used in Printing:

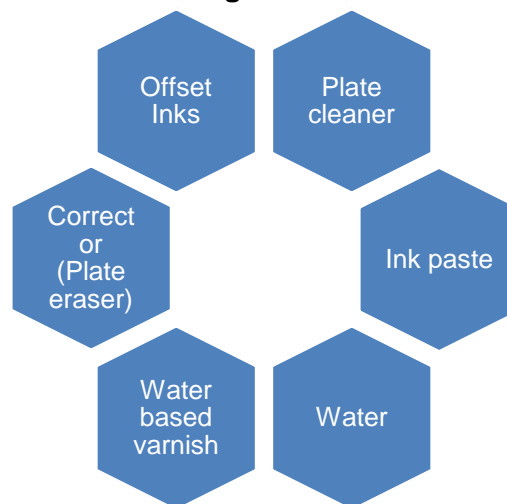

Procedure of non-toxic waste disposal:

Liquid non-hazardous (chemical) wastes with a pH between 6 and 10 may be flushed to the sanitary sewer (down the sink).

An aqueous (water-based) solution of any of the compounds in the list below is considered a **liquid non-hazardous chemical waste** and can be poured down the sanitary sewer.

Waste generators must perform a hazardous waste determination prior to disposal of all chemicals





Solids: Collect solids in disposable, non-leaking containers, labeled with contents, clearly marked as non-hazardous, and prepared for disposal





Liquids: Solutions containing only non-hazardous, water miscible liquid materials, pH between 6 and 9.5, can be disposed through the sewer system

An aqueous (water-based) solution of any of the compounds in the list below is considered a **liquid non-hazardous chemical waste** and can be poured down the sanitary sewer

Practical Activity 1/1:

Perform Waste Management		
Module: 4	Learning Unit: 3	Handle non-toxic chemicals
	Practical Description:	Tagging of containers of non-toxic chemical and storage of non-toxic waste to designated place. Disposal of inflammable and non-inflammable non-toxic chemical waste
Time:	04 hours	
Equipment	Folding machine	
Tools	N/A	
PPE	Uniform, Safety shoes, safety mask, Gloves	
Materials	Liquid dispose of container, Container for inflammable non-toxic chemical, Container for non-inflammable non-toxic chemical, Waste bin.	
Key Point	Keep tagging and storing of non-toxic material carefully	
Learning Outcome:	<ul style="list-style-type: none"> • Tag containers of non-toxic chemical as per instruction. • Store nontoxic waste at designated place. • Dispose-off inflammable non- toxic chemical waste as per instruction. 	
Precautions:	Ensure safety	
Instructions		Illustrations
<ol style="list-style-type: none"> 1. Prepare tags for non-toxic waste chemicals. 		

<p>2. Put the nontoxic waste in the container carefully.</p>	
<p>3. Store the nontoxic waste container at its proper place thoroughly.</p>	
<p>4. Segregate inflammable and non-inflammable non-toxic chemicals waste</p>	
<p>5. Dispose of flammable non-toxic chemical.</p>	

<p>6. Dispose of non-inflammable non-toxic chemical as per SOPs.</p>	 A circular prohibition sign with a red border and a diagonal slash over a black flame icon.
<p>7. Remove gloves, mask</p>	 A photograph of a person's head and shoulders wearing a white surgical mask and a dark blue shirt.
<p>8. Recheck no waste is left to dispose-off.</p>	 A photograph of a workshop floor with various tools, equipment, and a wooden workbench.
<p>9. Wash hands gently.</p>	 A circular sign with a blue background and the text 'WASH YOUR HANDS' in black. It features a black silhouette of hands being washed under a faucet with water droplets.

Learning Unit - :

LU 4: Manage solid waste

Overview: This learning unit defines types of solid waste and procedures to dispose it.

Reducing solid waste

To reduce solid waste, consider the following options:

Paper and board

- Keep your presses well-maintained to avoid spoilage.
- Set up the presses for optimum performance and train your staff to achieve minimum make-ready waste.
- Seek out the causes of spoilage and try to eliminate them.
- Make sure each job is fully signed-off by the pre-press area to avoid waste from proofing, copy or artwork mistakes.
- Consider improving efficiency by using better press maintenance.
- Find out if you can recycle paper or board in two grades. Non-inked or less inked paper can be worth more to recyclers, and if so, could bring you a better return.



Find out if it's easier and more economical to have your recycling contractor sort out the different grades of paper for you. Make blank pads from excess paper.

Non-paper substrate (plastics, metals, wood, flexible, glass, fabric, laminates)

If you don't print on paper but use another substrate, the recyclability of that material will be critical to reducing the costs of your operations.

Consider reusing or recycling screen printing frames where possible.

Plastics

Many plastics can be recycled, including shrink-wrap, but some contractors require the plastic types to be separated. Inks can be supplied in plastic cartridges that are reusable.

Metals

Metals are easily recycled. Separate them into different types to increase their value. Aluminum printing plates are commonly recycled as scrap metal.

Wood

Wood is a common printing waste. Some of it is reusable, such as pallets in good condition. You can also reuse wood as packaging for your products. Ask your suppliers if they can take back non-standard pallets.

Containers

Purchase products from suppliers that provide a collection, reuse or refill service for containers. Purchase ink and other products in containers that are made from easily recyclable materials.

Glass and some plastic containers may be able to be recycled. Check with your waste service contractor or your local Council. Segregating recyclable materials as much as possible from other waste streams will increase their value and reduce your waste disposal costs.

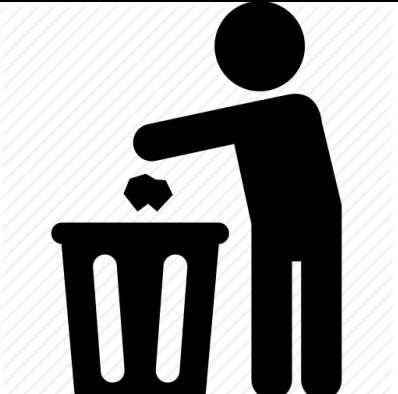
		Perform Waste Management	
Module: 4	Learning Unit: 4	Manage solid waste	
	Practical Description:	Sort and put solid waste in waste bin according to disposable categories, and store waste bins at designated place	
Time:	04 hours		
Equipment	N/A		
Tools	N/A		
PPE	Uniform, Safety shoes, Gloves		
Materials	Waste bins		
Key Point	Carefully sorting of solid waste		
Learning Outcome:	<ul style="list-style-type: none"> • Tag containers of printed & un-printed substrate waste as per instruction. • Sort substrate waste according to disposable categories • Store printed substrate waste in designated waste container. • Store un-printed substrate waste in designated waste container. 		
Precautions:	Ensure safety first		
Instructions		Illustrations	
1. Sort out solid waste according to disposable categories.			
2. Put solid waste in waste bin carefully.			

3. Store solid waste bin to its designated place.



4. Wash your hands gently.



Summary of the module:

- Waste management is one of the biggest environmental issues faced by printing industry today.
- The printing industry uses a variety of valuable raw materials many of which can be recycled.
- There are three major waste streams found in the printing industry:
 - a) **Solid waste** – in general printing environment solid waste could consist of empty containers, damaged plates
 - b) **Water waste** – water waste from printing operations may contain lubricating oils, waste ink, and clean-up solvents
 - c) **Air emissions** – printing operations produce volatile organic compound emissions from the use of cleaning solvents and inks,
- Best management practices create the most cost-effective way to decrease the amount of waste generated from operations. This includes a careful control of raw materials, practical scheduling, and job management
- The waste management provides a framework for managing waste: avoid; reduce; reuse; recycle; and dispose. Following are various methods to reduce waste in print presses.
- A toxic substance is a substance that can be poisonous or cause health effects. Products that we use daily, such as cleaners, alcohol, oil can also be toxic. Any chemical can be toxic or harmful under certain conditions.
- Nontoxic materials are not considered to be harmful or destructive to human health. It is to be noted that at some level, every substance is toxic.
- Substrate/paper waste is generally the largest waste stream and should be segregated to make sure it is being recycled to its fullest extent.
- Creation of waste - in the printing industry as well as at home - should be avoided as much as possible. If waste is nevertheless produced, it should be recycled, incinerated or treated appropriately.
- With careful choice of materials and good control of production processes, waste can be minimized to benefit both the printing company and the environment.

Frequently Asked Questions (FAQs)

Question	Answer
1. Why should I work safely with toxic material?	Toxic materials are substances that may cause serious harm to an individual if it enters the body.
2. Why should good ventilation system necessary for working with toxic chemicals?	Well-maintained ventilation systems remove toxic vapors, fumes or airborne dusts from the workplace
3. How should store containers of toxic material?	<ul style="list-style-type: none"> • Keep the amount of toxic material in storage as small as possible. • Inspect storage areas and containers regularly • Ensure that containers are tightly closed
4. How dispose of waste toxic material safely?	<ul style="list-style-type: none"> • Do not mix hazardous waste materials with regular garbage • Do not overfill liquid waste containers.
5. Why good housekeeping is important when working with toxic chemical?	Good housekeeping is a very important way to prevent exposure to toxic materials.
6. Describe about nontoxic materials?	Nontoxic materials are not considered to be harmful to human health. The toxicity must be evaluated in terms of quantity of material.
7. Describe about Liquids?	Solutions containing only non-hazardous, water miscible liquid materials, pH between 6 and 9.5, can be disposed through the sewer system
8. Explain about Solids?	Collect solids in disposable, non-leaking containers, labeled with contents, clearly marked as non-hazardous, and prepared for disposal
9. What do you know about air emission?	Air emissions – printing operations produce volatile organic compound emissions from the use of cleaning solvents and inks.

10. How can you briefly explain water waste?	Water waste – water waste from printing operations may contain lubricating oils, waste ink, and clean-up solvents
--	---

Self-Assessment

(MCQs)

Please mark the correct one from the given options. You can check your answer with the Answer Key at the end of this module

Q 1. Waste management are all the activities and actions required to manage waste from its inception to it's

- a) packing
- b) burning
- c) final disposal
- d) Storage

Q 2. All of the following are categories of waste, except:

- a) industrial
- b) Litter
- c) Hazardous
- d) Municipal

Q 3. Hazardous waste.

- a) Is flammable
- b) Is corrosive
- c) Is toxic
- d) all choices are correct

Q 4. The key component of waste management is:

- a) Safety
- b) keeping an eye on waste
- c) waste reduction
- d) All of these

Q 5. The sum of all the waste produced by individuals, industries, mining, and agriculture is referred to as:

- a) the waste stream
- b) trash
- c) municipal solid waste
- d) Recycling

Q 6. There are _____ major waste streams found in the printing industry:

- a) Solid waste
- b) Water waste
- c) Air emissions
- d) All of above

Q 7. Make sure each job is fully _____ by the pre-press area to avoid waste from proofing, copy or artwork mistakes.

- a) Signed-in
- b) Signed-off

- c) Described
- d) None of above

Q 8. Collect _____ in disposable, non-leaking containers, labeled with contents, clearly marked as non-hazardous, and prepared for disposal

- a) Solids
- b) Liquids
- c) Solution
- d) None of above

Q9. The toxicity must be evaluated in terms of material's _____.

- a) Quality
- b) Quantity
- c) a & b both
- d) None of above

Q10. _____ Ventilation systems remove toxic vapors, fumes or airborne dusts from the workplace.

- a) Well-maintained
- b) Sequenced
- c) Horizontal
- d) Vertical

Answer Key

MCQ No.	Correct Answer
1	c
2	b
3	d
4	d
5	a
6	d
7	b
8	a
9	b
10	a

POST PRESS OPERATIONS (Publishing)

Learner Guide

National Vocational
Certificate Level 3

Version 1 - December 2019

Module-5

Module 5: - Develop professionalism

Learning Outcomes:

After completion of this module the learner will be able to:

- LU1: Participate in in-house training
- LU2: Participate in outdoor training
- LU3: Attend trade shows workshop, seminars
- LU4: Utilize internet
- LU5: Prioritize job schedule

Learning Unit - :

LU 1: Participate in in-house training

Overview: This learning unit describes the importance of being a good team player, identification of TLM /curriculum. Finally the importance and Benefits of latest machining techniques and developments.

Importance of being a good team player:

Pressroom is run by a team; if one fails performance decline has a cascading effect. A team player does not only do his/her task well but also helps his/her fellow team members to do well. In a pressroom your inputs are someone else's output and your output is someone else's input, if one deliverable in this chain is flawed the final result is flawed thus rendering all the hard work useless.



Effective teamwork in the workplace helps drive the organization towards success.

Here are some qualities that can make a team player outstanding in the workplace:

1. Show Genuine Commitment

Team players are genuinely committed to their cause. Good team players might make sure they are in the work place when needed, but great team players will make "work" time worth it and contribute as much as possible. They always strive for excellence.

Remember:

In a pressroom your inputs are someone else's output and your output is someone else's input.

2. Be flexible

Instead of sitting on the bench watching the rest of the crew perform, an outstanding team player wants to see the magic happen through his/her efforts as well. They are flexible to the situations thrown their way, and they participate and tackle challenges without showing too many signs of stress or pressure.

3. Don't stay in the shadows

It is not in your interest to just sit quietly and get your work done. It's a good thing to involve others, as long as you are not bothering people with questions you already know the answer too. Great team players come to their teammates having prepared their ideas clearly.

4. Be reliable and responsible

An excellent team player will be reliable and responsible. They complete the tasks in order of priority, not necessarily in order that they're given. When you're not sure of what should take priority, ask your supervisor.

5. Actively listen



You are only a team player if you respectfully consider the viewpoints and ideas of other people as well. This is why diverse teams have the potential to be so effective, and it all depends on active listening.

6. Keep your team informed

Share your opinion, ideas and expertise without trying to come up with a plan for taking credit for it.

Transparency is a key on a team, so keep your team members informed. Planning for your own success is important, but your career progression may have a lot to do with how you communicate with other team members.

7. Always be ready to help

Even if it is not in your job description, be generous with advice to help team members. For example, if a member is having trouble with a technology tool that is easy for you, offer to sit down with him and show him what you know.

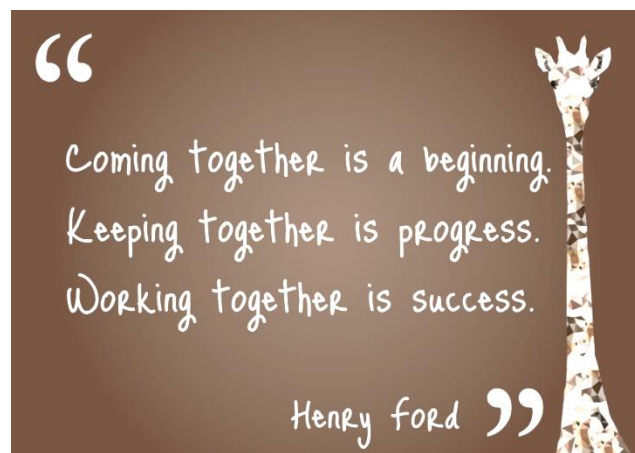

8. Support and respect others

It is important to become more self-aware of how you treat others. Remember, you'll receive respect when you give it to others. An ideal team player knows how to have fun, but he would never do it at someone else's expense.

9. Be a problem-solver

Your team leader may be working on solving problems, but there is no reason why you cannot offer solutions yourself. Your teammates will appreciate your skills and this may pay off later when your supervisor is assessing your progress.

10. Recognize when you are wrong

A good team player will back off an idea when it becomes clear it's not the right path. If you believe strongly that your team is making a mistake, you can find a way to come back to the issue when the time is right, but being a stubborn stick in the mud is not quality of a good team player.

Teaching Learning Material (TLM):

Teaching learning materials (TLM) are, tools, which are used by teachers to help learners to learn concept with ease and efficiency. It also helps the learners to achieve the learning outcomes after classroom teaching and learning.

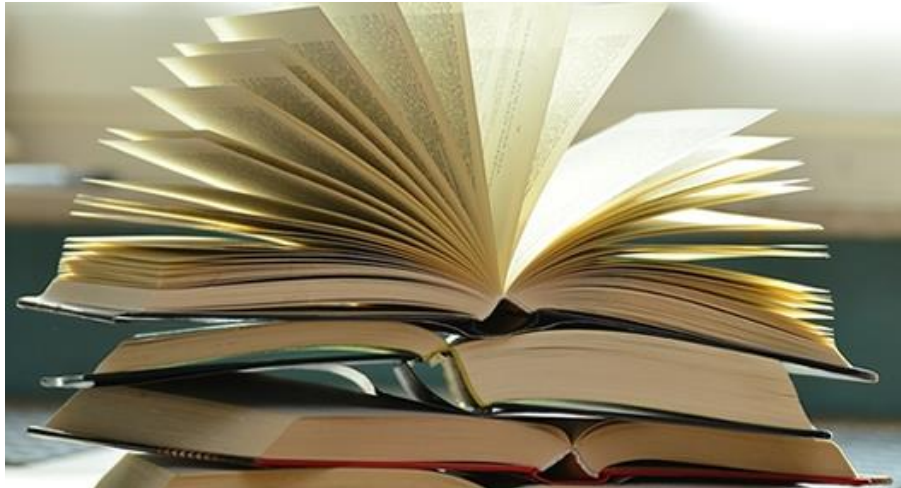

Examples

Do you know?

Teaching material can support student's learning and increase their success.

Teaching materials can refer to a number of teacher resources; however, the term usually refers to concrete examples, such as worksheets or manipulative (learning tools or activities that students can handle to help them gain and practice facility with new knowledge). Teaching materials are different from teaching “resources”, the latter including more theoretical and intangible elements.

Students Learning Support

Learning materials are important because they can significantly increase student achievement by supporting student learning.

Curriculum:

A **curriculum** is the combination of instructional practices, learning experiences, and students' performance assessment that are designed to bring out and evaluate the target learning outcomes of a particular course.

Typically refers to the knowledge and skills trainees are expected to learn, which includes the learning standards or learning objectives they are expected to meet; the units and lessons that teacher teach. The assignments and projects given to learners; the books, materials, videos, presentations and readings used in a course and the tests, assessments and other methods used to evaluate learners.

Benefits of latest machining techniques and developments:

Industry today is moving at a breakneck pace. Keeping up to speed or ahead of the curve is vital for your business in order to meet the demands of today's customers.

Technology has been the standard in the printing world since 1903. It is a traditional solution perfect for customers looking for high volume printings, cost effective methods, flexibility and the most important thing: top quality results.

A really impressive degree of details and clarity is one of the most major benefits of printing.

Getting the latest knowledge of the technology and evolving with the market trends are the key factors to progress.

- 1.) Low Error
- 2.) Less Material Waste
- 3.) Consistent Product Quality
- 4.) Improved Workflow
- 5.) Reduced Turnaround Time
- 6.) Faster Production Cycles



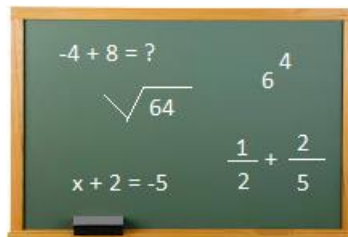

Press room mathematical skills during training:

Understanding of basic arithmetic skills like addition, subtraction, multiplication and division is necessary to perform better role of press room operator.



Practical Activity 1/1:

		Develop professionalism	
Module: 5	Learning Unit: 1	Participate in in-house training	
	Practical Description:	Clean workstation	
Time:	03 hours		
Equipment	N/A		
Tools	Cleaning cloth, Dustpan		
PPE	Proper dress code, safety gloves, safety shoes		
Materials	Cleaning agent, caution signs		
Key Point	Oil and water on the floor should be properly cleaned so that no residue is left		
Learning Outcome:	<ul style="list-style-type: none"> • Identify latest training needs according to recent printing industry demands. • Get enrolled in advance press training course. • Follow training institute's policies for professional development. • Perform training task mentioned in TLM. 		
Precautions:	When using hazardous chemicals, read manufacturer's instructions for safety		
Instructions		Illustrations	
<ol style="list-style-type: none"> 1. Check for dust, debris, water and oil spill around the work floor 			

<p>2. Pick up a clean cloth and wipe the floor</p>	
<p>3. Collect the dust and debris in a dustpan</p>	
<p>4. Ensure cleanliness of oil spots on the floor/working table</p>	
<p>5. Perform drying of wet floor with the help of cloth.</p>	
<p>6. Mark the freshly cleaned area with a caution sign</p>	

Learning Unit - :

LU 2: Participate in outdoor training

Overview: This learning unit describes the importance of Industrial Kaizen and housekeeping through check sheet. It also emphasizes to applying basic mathematical and Basic English skills in the pressroom this learning unit focuses on keeping in touch with press training providers. It states importance and methods of time management and also helps the learner to identify press room Key Performance Indicators (KPIs)

Importance of Industrial Kaizen:

Remember:

Job training empowers people to realize their dreams and improve their lives

KAI ZEN
 改善
 Change for Good

Kaizen is a manufacturing tool which improves quality, productivity, safety, and workplace culture. This occurs by applying small daily changes that yield major improvements over time. Kaizen comes from two Japanese words: Kai (change) and Zen (good). Over time, it became known as “continuous improvement.” Unlike many business practices Kaizen’s strength comes from requiring all workers—from the CEO to the shop floor assistant—to contribute suggestions to improve the business.

Kaizen provides one simple principle: look at how things can be improved, improve them, and then improve them again and again. You can do this by using Plan-Do-Check-Act (PDCA), empowering workers to find problems, develop solutions and apply solutions in a continuous cycle.

Using Kaizen will result in many benefits. Some of the expected benefits will be:

- Increased productivity
- Improved quality
- Better safety
- Lower costs
- Improved customer satisfaction

Housekeeping:

To work efficiently, checklist is important so that steps are carried out in the intended sequence. Pressroom housekeeping means to keep the printing workstation clean and organized. The following steps may be taken:

- Labeling of tools and equipment so that they do not get mixed with other machine operators
- Organizing tools in order for an easy Access.
- Ensure routine Cleaning of the work table and machine.
- Dispose-off waste in the designated area.



BEFORE



AFTER

Importance and methods of time management:

Time Management refers to managing time efficiently so that the right time is allocated to the right activity. Effective time management allows individuals to assign specific time slots to perform activities as per their importance. Time Management refers to making the best use of time as time is always limited.

Ask yourself which activity is more important and how much time should be allocated to the same in consultation with supervisor? Know how to prioritize the jobs. Time Management includes:

- i. Effective Planning
- ii. Setting goals and objectives
- iii. Setting deadlines
- iv. Prioritizing activities as per their importance
- v. Spending the right time on the right activity

For Effective Time Management one needs to be:

- i. **Organized** – Reduce pending tasks. Put important documents, tools and consumables in their respective place with proper labeling so that your equipment do not get mixed with other colleague's equipment. It saves time which goes on unnecessary searching
- ii. **Don't misuse time** - Do not kill time by loitering or gossiping around. Concentrate on your work and finish assignments on time. Remember what you are being paid for, it is our social as well as religious obligation to 'Halal' your earnings. Don't wait till the last moment to submit your work.

iii. **Be Focused** - One needs to be focused for effective time management. Develop the habit of using planning documentation for better time management. Set reminders for periodical maintenance and tools check.

Keep in touch with press training providers:

To keep on progressing, you need to upgrade your knowledge and skill which can be acquired through trainings. You should keep in touch with your supervisor and inform him about your eagerness to learn, so he/she may remember your name for next training session organized by the industry.

Skills above and beyond the basics of printing, can give you a professional advantage.

Remember:

Purpose of training is to tighten up the slack, toughen the body and polish the spirit.

Here are the five ways to keep your knowledge, skills and abilities up-to-date.

1. Take Professional Development Courses

Professional development courses can help you expand your professional skill set e.g. Supply chain workshop, Total Quality Management workshop etc.



2. Utilize Online Resources





The Internet is a limitless source of information and training resources (Like You Tube and Lynda.com etc.). Online training courses are particularly convenient because they are affordable and flexible some OEMs published tutorial videos online which particularly useful.

3. Attend Professional Events

Professional events are valuable ways to learn about growth and development in printing industry. Local companies, business associations, and professional groups often host seminars, exhibition, forums, or workshops that can give you direct access and insight to experts in your profession. Print Pak is the largest printing exhibition organized by Pakistan Association of Printing and Graphic Arts Industry which also includes free training workshop and seminars by local and international resource persons.

Practical Activity 1/1:

Develop professionalism		
Module: 5	Learning Unit: 2	Participate in outdoor training
	Practical Description:	Collect information about the new printing training courses
Time:	03 hours	
Equipment	Computer with internet	
Tools	Training brochures	
PPE	N/A	
Materials	Tools/equipment list, Training provider's brochures, TLM	
Key Point	Stay focused when browsing for new training opportunities	
Learning Outcome:	<ul style="list-style-type: none"> • Promote Kaizen in printing industry. • Implement 5S's at work place. • Maintain schedule chart according to organizational policies. • Provide logistic support for press room machinery during maintenance. 	
Precautions:	Identify a field of work to get your advanced training in.	
Instructions		Illustrations
<ol style="list-style-type: none"> 1. Make a list of your current activities in the pressroom and identify your weak points which needs to be improved 		
<ol style="list-style-type: none"> 2. Take input from your classmates and trainer and ask them what should be your next training 		

<p>3. Ask your trainer which institutes offer training in the mentioned functions collect brochures if available</p>	
<p>4. Browse the internet for specific printing training institutes</p>	
<p>5. Note down the contact information for the course being offered</p>	
<p>6. Call the institute and ask for the timing and duration of the course</p>	
<p>7. Inform your trainer/supervisor about the available course and timings and ask them if you can join advance course without disrupting current activities or you will need an exemption from current training/work</p>	

8. Join the advance training course



Learning Unit - :

LU 3: Attend trade shows workshop, seminars

Overview: After completion of this learning unit the learner will be able to understand the benefits of latest printing technologies by getting involved in seminars/workshop and by reading related books/magazines.

Trade show:

An industrial event where different or same trade organization show case their latest products, services and techniques. It is a platform to meet industry partners and customers and to understand recent market trends and explore new technologies.

It is necessary for a printing machine operator that he/she prepare himself / herself for the requirements of new techniques in printing industry. It is very important to attend seminars with devotion and concentration to get a wide variety of informative topics related to printing industry.

Industrial visit:

It is also a part of professional courses, during which students pay visit to the relevant industry to get exposure to the real working environment.

Other best way to get knowledge and information is through watching videos/documentaries, and browsing on internet related to your interest areas.

Need of skill sets by getting involved in seminars:

Professional personnel attend following events to enhance their knowledge and skills:

- Seminar
- Workshops
- Meetings
- Discussions
- Competitions
- Exhibitions

Attending such kind of above programs can improve the following skill sets:

- Improving communication skills
- Gaining expert knowledge
- Networking with others and renewing motivation
- Enhance confidence level

Read books/magazines related with mechanical manufacturing trade:

Short keys for MS office:

There are many general program shortcuts in Microsoft office that make it easier for you to do everything from save your document to undo a mistake.

60 Most useful Microsoft Office shortcut keys it's useful for all works.

Keys	Action
Ctrl + BackSpace	Deletes Word To Left of Cursor
Ctrl + Del	Deletes Word To Right Of Cursor
Ctrl + Shift + F	Change the Font
Ctrl + Shift + L	Quickly Create A Bullet Point
Ctrl + Right	Go To The Word To The Right
Ctrl + Left	Go To The Word To The Left
Ctrl + DOWN	Arrow To Paragraph Down
Ctrl + Up	Arrow To Paragraph Up
Ctrl + End	Go TO The End Of The Document
Ctrl + Home	GO To The Start of The Document
Ctrl + Shift + Spacebar	Create A Non - Breaking Space.
Ctrl + Spacebar	Remove Character Formatting
Ctrl + Shift + >	Increase Font Size One Point
Ctrl + Shift + <	Decrease Font Size One Point
Ctrl + B	Toggle the Bold Attribute
Ctrl + C	Copy Selected Text To The Clipboard
Ctrl + E	Aligns The Line Or Selected Text To The Center Of The Screen
Ctrl + D	Open the Font Preferences Window
Ctrl + I	Italic Highlighted the Selection
Ctrl + J	Aligns The Line Or Selected Text To The Justify Of The Screen
Ctrl + K	Insert a Hyperlink
Ctrl + L	Aligns The Line Or Selected Text To The Lift Of The Screen
Ctrl + M	Indent the Paragraph

Ctrl+Q	Remove paragraph Formatting
Ctrl + R	Aligns The Line Or Selected Text To The Right Of The Screen
Ctrl + S	Save The Open Document
Ctrl + T	Create A Hanging Indent
Ctrl + U	Toggle the Underline Attribute
Ctrl + V	paste Text From Clipboard
Ctrl + W	Close The Currently Open Document
Ctrl + X	Cut Selected Text TO The Clipboard
Ctrl + Y	Redo The Last Action
Ctrl + Z	undo The Last Action
F1	Access Online Help Or The Office Assistant
F2	Move Text Or Graphics
F3	Insert An Autotext Entry
F4	Repeat The Last Action
F5	Choose The Go To Command
F6	Go To Next Pane Or Frame
F7	Launch The Spelling And Grammar Check
F8	Extend A Selection
F9	Update Selected Fields
F10	Activate The Menu Bar
F11	Go to the Next Field
F12	Choose The Save As Command
Shift + F1	Start Context – Sensitive Help Or Reveal Formatting
Shift + F2	Copy Selected Text
Shift + F3	Change The Case Of Letters
Shift + F4	Repeat A Find Or Go To Action
Shift + F5	Move To A Previous Revision
Shift + F6	Go To The Previous Pane Or Frame
Shift + F7	Choose The Thesaurus Command
Shift + F8	Shrink a Selection
Shift + F9	Switch Between A Field Code And Its Result

Shift + F10	Display A Shortcut Menu
Shift + F11	Go To The Previous Field
Shift + F12	Choose The Save Command

Production plan and its advantages:

In order to develop production plans, the production planner or production planning department needs to work closely together with the marketing department and sales department. They can provide sales forecasts, or a listing of customer orders. The "work is usually selected from a variety of product types which may require different resources and serve different customers. Therefore, the selection must optimize customer-independent performance measures such as cycle time and customer-dependent performance measures such as on-time delivery.

- Reduced labor costs by eliminating wasted time and improving process flow.
- Reduced inventory costs by decreasing the need for safety stocks and excessive work-in-process inventories.
- Optimized equipment usage and increased capacity.

Practical Activity 1/1:

		Develop professionalism	
Module: 5	Learning Unit: 3	Attend trade shows workshop, seminars	
	Practical Description:	Attending the shows related to the printing industries, seminars and workshops for knowledge on latest printing techniques and innovative technologies.	
Time:	03 hours		
Equipment	N/A		
Tools	N/A		
PPE	N/A		
Materials	National and International Magazines and Operation Manual		
Key Point	Ensure access to the relevant printing information		
Learning Outcome:	<ul style="list-style-type: none"> • Adopt upcoming market trends in printing trade by attending workshop and seminar. • Participate in skill test for professional development with concentration. • Participate in skill up-gradation courses with devotion. • Participate in professional seminars with concentration to acquire first hand industrial knowledge. • Participate in industrial visits on schedule. • Consult senior experts to get advice. • Watch videos/documentaries related with printing and packaging industry. • Perform internet browsing related to printing industry. 		
Precautions:	Gain first hand industrial knowledge by participating in professional seminars.		
Instructions		Illustrations	

<p>1. Visit printing exhibition to get exposure of latest techniques and technologies.</p>	
<p>2. Attend seminars to get updated with the latest printing techniques.</p>	
<p>3. Read printing magazines and improve the knowledge up to date with all the news and innovative technologies.</p>	
<p>4. Attend workshops related to the printing press for knowledge of the workflow of a printing press</p>	

Learning Unit - :

LU 4: Utilize internet

Overview: This learning unit deals with effective communication by the use of Internet. It will help trainee to understand the procedure of creating new email, E-mail writing ethics and email sent confirmation.

Electronic mail: (email or e-mail) is a method of exchanging messages between people using electronic devices.

An **e-mail account** is an arrangement with a company which allows you to send and receive emails.

An **email address** is a unique identifier for an email account. It is used to both send and receive email messages over the Internet. Similar to physical mail, an email message requires an address for both the sender and recipient in order to be sent successfully.

Every email address has two main parts: a username and domain name. The username comes first, followed by an (@) symbol, followed by the domain name. In the example below, "mail" is the username and "techterms.com" is the domain name.

mail@techterms.com

E-mail Writing Ethics:

It is imperative that you remain professional during email communication and also ensure that information shared is approved by your supervisor as email can access at any time in the future.

Remember

Communication- the human connection- is the key to personal and career success.

Paul i.Mever

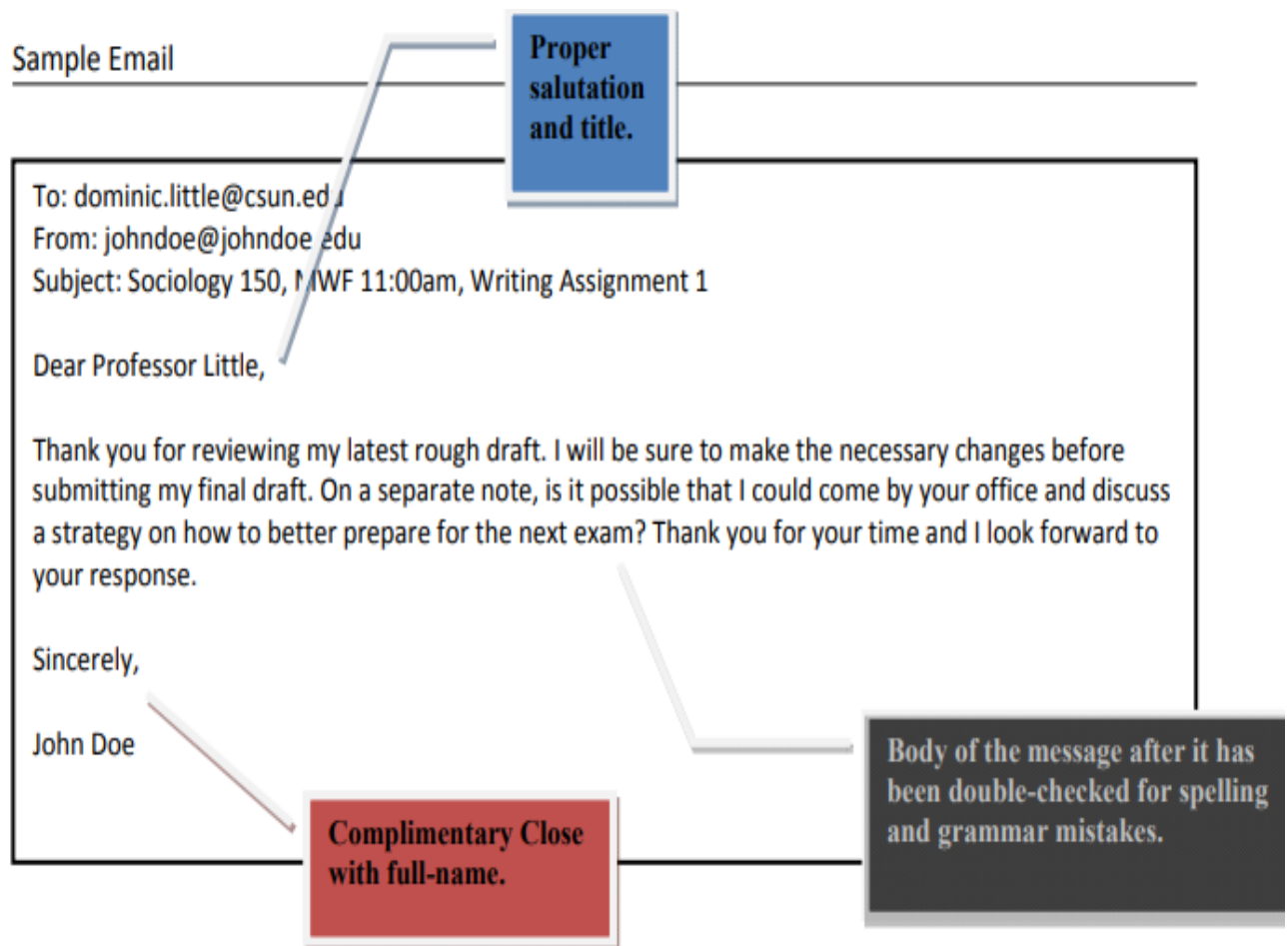

Answer swiftly

Your customers send you email because they want quick responses. The golden rule for email is to reply within 24 hours

Use a meaningful Subject line

Try to use a subject that is meaningful to the recipient as well as yourself

Use the BCC Field

When you want to keep recipients hidden from people on the "To" field, then you add them to the Bcc field.

Read your email

Before you send the email treat it like any other official company document. Read it before you send it. Spelling and grammar errors are just as unfortunate in email as anywhere else in your corporate correspondence

Don't attach unnecessary files

Wherever possible try to compress attachments and only send attachments when they are productive.

Browsing techniques to find appropriate web site

A **web** search engine is a software system designed to search for information on the World Wide **Web**. The search results are generally presented in a line of results often referred to as search engine results pages (SEROs). ... Some search engines also mine data available in databases or open directories.



10 tips for smarter, more efficient Internet searching

- 1: Use unique, specific terms. ...
- 2: Use the minus operator (-) to narrow the search. ...
- 3: Use quotation marks for exact phrases. ...
- 4: Don't use common words and punctuation. ...
- 5: Capitalization. ...
- 6: Drop the suffixes. ...
- 7: Maximize AutoComplete. ...
- 8: Customize your searches.

Method of e-mail sent confirmation:



By using suitable phrases, we can make the confirmation of email received at receiver end. Following are the phrases we can use in E-mails:

- I'd like to confirm ...
- Just writing to confirm ...
- Tuesday is good for me. Please send me an email by 5 pm today to confirm this...
- Looking forward to seeing/meeting ...

Identify internet browsing/search engine

To perform a search, you'll need to navigate to a search engine in your web browser, type one or more keywords—also known as search terms—then press Enter on your keyboard. In this example, we'll search for recipes. After you run a search, you'll see a list of relevant websites that match your search terms.

Practical Activity 1/1:

Module: 5	Develop professionalism	
	Learning Unit: 4	Utilize internet
	Practical Description:	Communication via E-mail with the help of internet.
Time:	03 hours	
Equipment	Computer with internet	
Tools	N/A	
PPE	N/A	
Materials	Handout on related topic, Flip Chart, Pen, Pencil ,Paper .Note book	
Key Point	Software downloading, data searching on different webs, fast communication and correspondence with concerns personals with the help of electronic mail.	
Learning Outcome:	<ul style="list-style-type: none"> • Ensure format or structure of the correspondence is according to company's practice. • Browse website as per desire. • Download related software as per desire. • Perform required communication via internet with in specified time limits. 	
Precautions:	N/A	
Instructions		Illustrations
1. Click on the internet explorer or Google chrome icon for open any web page.		 

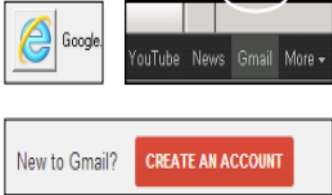
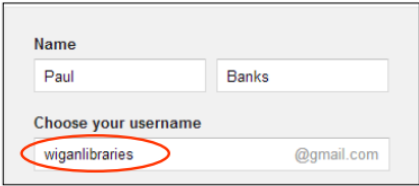
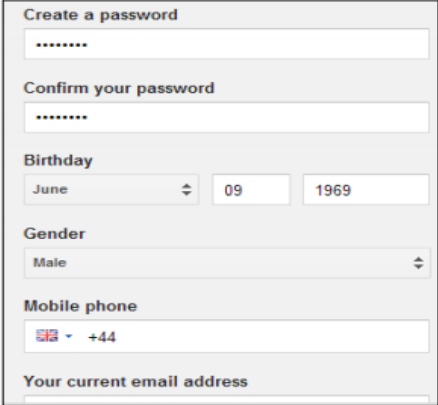
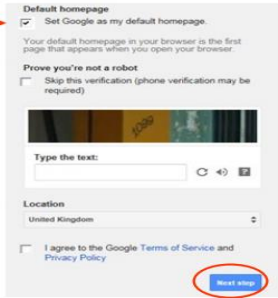
<p>2. Click on address box and browse your required web page.</p>	
<p>3. Click on the google link on the people's network. Then click on the Gmail link near the top left of the page. If using a computer elsewhere perform an Internet search for Gmail. Click on create an account.</p>	
<p>4. Choosing your email address to set up your new account, Google needs some information about you. Type your first and last names. To create an email, you need to choose a username. Your email address will be your username followed by '@gmail.com'.</p>	
<p>5. Choosing your password that is 8 characters or more. Make sure your password is secure and one that you can remember! Secure passwords include combinations of upper and lowercase letters and numbers. Verifying your Gmail account type your birthday and gender. Enter your mobile telephone number or an alternative email address if you have one.</p>	
<p>6. Prove you're not a Robot! You may want to uncheck the box next to set Google as my default homepage'. Type in the letters or digits as they appear on the screen. Agree to the terms of service by checking the box.</p>	

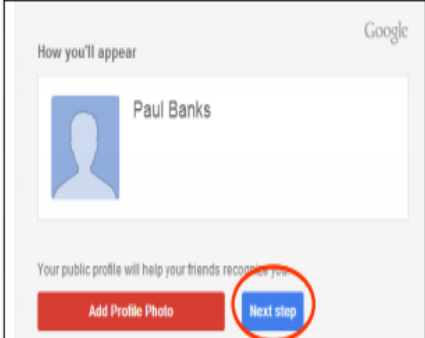
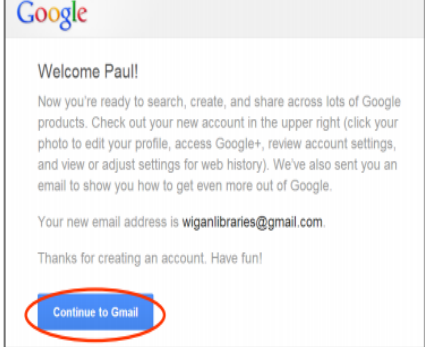
<p>7. Click on next step. (you can add a profile picture at a later stage)</p>	 <p>The screenshot shows a Google account creation progress screen titled "How you'll appear". It displays a placeholder profile picture and the name "Paul Banks". Below the name, there is a red button labeled "Add Profile Photo" and a blue button labeled "Next step". The "Next step" button is circled in red.</p>
<p>8. You have created an email account! To start using email click on continue to Gmail.</p>	 <p>The screenshot shows a Google account creation completion screen titled "Welcome Paul!". It contains text about the new account and a blue button labeled "Continue to Gmail". The "Continue to Gmail" button is circled in red.</p>

Learning Unit - :

LU 5: Prioritize job schedule

Overview: Production planning and control is a tool, available with management to achieve desired production/target. Thus, a production system is comprised of four factors i.e. quantity, quality, cost and time. This learning unit describes the production plan and its advantages.

Press room Key Performance Indicators (KPIs)

Key Performance Indicator (KPI) is a tool, used in a workplace to measure that how effectively they are achieving their goals. KPI is a way for businesses to quantify their business objectives so they can regularly check up on their performance and determine where they are successful and where they need to improve.

In a press room KPIs may be as follows.

- Percentage of defective prints compared to total number of units produced
- Percentage of on-time deliveries
- Consumable efficiency
- Job turn over

Production plan:

Production planning starts with the analysis of the given data, i.e., demand for products, delivery schedule, availability of required material and availability of workforce etc. On the basis of the information available, a scheme of utilization of firm's resources like machines, materials and manpower are worked out to achieve the target in the most efficient way.

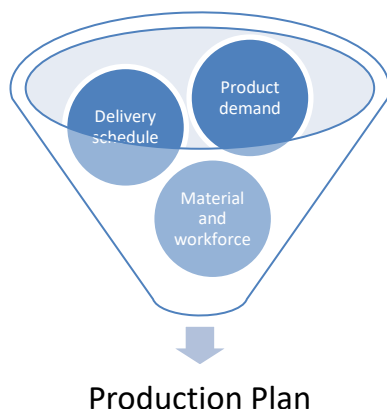

Do you know?

Production planning and control can be defined as the "direction and coordination of firm's resources towards attaining the prefixed goals".

Remember:

The key is

"Not to prioritize what's on schedule, but schedule your priorities".

The objective of production planning and control is **to manage the materials and organizational capacities based on the customer needs**. Thus production planning

enables the industry professionals to deliver high quality products and fulfill customer demand efficiently.

Production Plan Example:

Production Plan									
SORK-1					SORK-2				
Shift	Job No	Job Name	Time (Hours)	Delivery date	Shift	Job No	Job Name	Time	D.D
MACHINE AND WORKSTATION CLEANING									
21 A	G-166 A		3.00	10.11.17	21 A	G-004 A		4	30.11.17
23 A	G-134 G-135		1.00	10.11.17					
1 HOUR LUNCH AND PRAYER BREAK									
24 A	G-262 A		1	10.11.17	24 A	G-008 A		3	30.11.17
24 A	G-262 B , D		2	10.11.17	25 A	G-0066 A		3	30.11.17
24 A	G-263 A		2	10.11.17	26 A	G-0023 A		1	30.11.17
MACHINE AND WORKSTATION CLEANING									



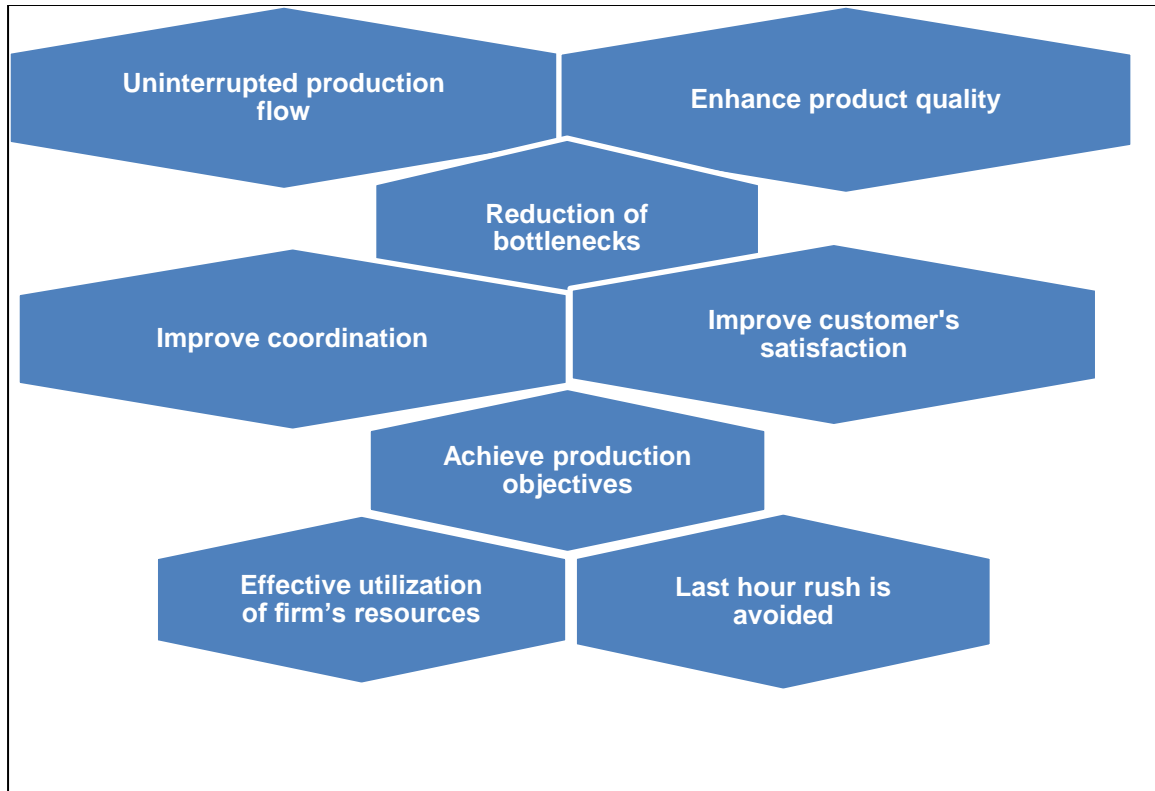

Advantages of maintaining production plan:

The implementation of production planning yields various advantages to any industry for functional activities, which includes the following:

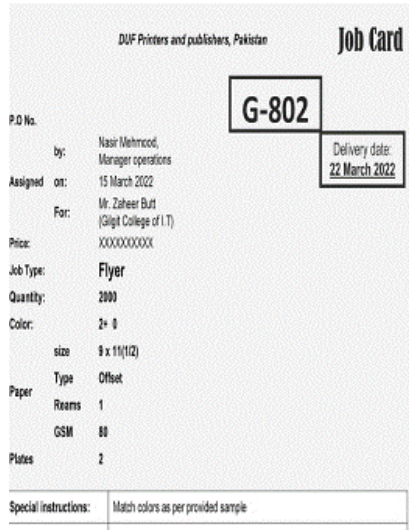

Practical Activity 1/1:

Module: 5	Develop professionalism	
	Learning Unit: 5	Prioritize job schedule
	Practical Description:	Interpret docket / job card
Time:	03 hours	
Equipment	N/A	
Tools	N/A	
PPE	N/A	
Materials	Docket / job card, log book	
Key Point	It is important to correctly interpret the job card in order to avoid confusion	
Learning Outcome:	<ul style="list-style-type: none"> • Interpret production plan as per supervisor's instruction. • Create daily schedule according to priority of production plan. • Comprehend material priorities for hindrance less production, • Develop list of required tools for hindrance less production, • Calculate time required for production • Determine sequence of activities. • Report delays to superior in prescribed manners. 	
Precautions:	Read carefully, do not miss out information.	
Instructions	Illustrations	
1. Collect the docket/job card		

<p>2. Match the details with the provided equipment, materials and tools</p>	
<p>3. Match the size of substrate and number of plates provided with the docket/ job card.</p>	
<p>4. If found any error, report to the supervisor</p>	
<p>5. Note the time required for the job and the time available in the shift</p>	
<p>6. Start the printing process</p>	

Summary of the Module

- To keep on progressing, you need to upgrade your knowledge and skill which can be acquired through trainings.
- A pressroom operator must have basic Math's knowledge for better material handling and calculation.
- A good pressroom operator should also have Basic English since most of the machine manuals and instructions are in English.
- A team player does not only do his/her task well but also helps his/her fellow team members to do well.
- Teaching learning materials (TLMs) are, tools, which are used by teachers to help learners to learn concept with ease and efficiency. TLMs also help learners to achieve the learning outcomes after classroom teaching.
- A *curriculum* is the combination of instructional practices, learning experiences, and students' performance assessment that are designed to bring out and evaluate the target learning outcomes of a particular course.
- Kaizen comes from two Japanese words: Kai (change) and Zen (good). Over time, it became known as "continuous improvement." Using Kaizen will result in many benefits. Some of the expected benefits will be:
 - Increased productivity
 - Improved quality
 - Better safety
 - Lower costs
 - Improved customer satisfaction
- 5S is the foundation of all improvements and it is the key component of establishing a work friendly press room. 5S stands for: Sort, Set in order, Shine, Standardize and Sustain.
- Key Performance Indicators (KPI) is a way for businesses to quantify their business objectives so that they can regularly check up on their performance and determine where they are successful and where they need to improve.
- Time Management refers to managing time efficiently so that the right time is allocated to the right activity. Effective time management allows individuals to assign specific time slots to perform activities as per their importance.
- Pressroom housekeeping means to keep the printing workstation clean and organized.
- Trade show is a platform to meet industry partners and customers and to understand recent market trends and explore innovative technologies. Professional personnel attend following events to enhance their knowledge and skills:
 - Seminars
 - Workshops
 - Meetings
 - Discussions
 - Competitions
 - Exhibitions

Frequently Asked Questions (FAQs)

Question	Answer
1. What will be the timing of training delivered at the workplace?	Training would be delivered in the routine working hours.
2. How can I be a team player if I concentrate on my job only?	Printing is a team work. Being good at your own job is not the only key to success. Helping coworkers and working as a team is equally important.
3. Is time management of the workplace is responsibility of the machine operator?	Yes, because time management is an integral part of a production plan.
4. Why participation in trade shows, workshops and seminars is important?	Participation in the trade shows, workshops and seminars is important as it familiarize the participants with new printing techniques and knowledge.
5. What do you mean by latest techniques in printing?	Latest printing techniques means ways to perform the job in a smarter and faster manner.
6. What are the benefits of latest printing techniques?	Benefits of latest printing techniques are <ul style="list-style-type: none"> • Good quality printing • Faster work flow • Less wastage of time and material
7. Why it is important to read printing related books and magazine?	It keep updated with the news in the industry and knowing what other competitor and business institutions are doing.
8. What is production planning	Direction and coordination of firms' resources towards attaining the prefixed goals.
9. What does production plan demand?	Product and Delivery Schedule
10. What is the advantage of production planning?	Production planning helps the company to supply quality products efficiently.

Self-Assessment

(MCQs)

Please mark the correct one from the given options. You can check your answer with the Answer Key at the end of this module

Q 1: With whom should you keep in touch in order to know about the new training opportunities in your organization?

- a) Family
- b) Supervisor
- c) Current affairs
- d) Other companies

Q 2: Most product descriptions and machine manuals are in:

- a) English
- b) Russian
- c) Binary code
- d) American

Q 3: In a pressroom, it's important to be a:

- a) Fast talker
- b) Religious preacher
- c) Good team player
- d) Runner

Q 4: KPI means?

- a) Kilo per inch
- b) Knowledge press integration
- c) Potassium per Indium
- d) Key Performance Indicator

Q 5: What is Kaizen?

- a) A Japanese sword
- b) A management method
- c) Judo technique
- d) Lab chemical

Q 6: Which of the following is objective of production planning?

- a) Meetings
- b) Result
- c) Quality
- d) None of the above

Q 7: To do good time management, one needs to be:

- a) Lawful
- b) Fit
- c) Organized
- d) Tough

Q 8: What are trade shows?

- a) Dinner gathering
- b) Where companies show their new technology and techniques.
- c) Game shows
- d) Class.

Q 9: Benefit of workshops:

- a) Enhance skills
- b) Develop healthy life style.
- c) Develop eating habit.
- d) Meeting friends.

Q 10: Who should attend trade shows?

- a) People related to same industry
- b) Hotel staff.
- c) Cricket team.
- d) Teachers

Answer Key

MCQ No.	Correct Answer
1	b
2	a
3	c
4	d
5	b
6	c
7	c
8	b
9	a
10	a

National Vocational and Technical Training Commission (NAVTTTC)

 Plot 38, Kirthar Road, Sector H-9/4, Islamabad, Pakistan

 +92 51 9044 322

 +92 51 9044 322

 info@navttc.org

 www.navttc.org