



Co-funded by the European Union



german cooperation
DEUTSCHE ZUSAMMENARBEIT



Norwegian Embassy
Islamabad



INDUSTRIAL GARMENT EXPERT



© TVET SSP

LEARNER GUIDE

National Vocational Certificate Level 2

Version 1 - June, 2019



Implemented by
giz Deutsche Gesellschaft
für Internationale
Zusammenarbeit (GIZ) GmbH

Published by

National Vocational and Technical Training Commission
Government of Pakistan

Headquarter

Plot 38, Kirthar Road, Sector H-9/4, Islamabad, Pakistan
www.navttc.org

Responsible

Director General Skills Standard and Curricula, National Vocational and Technical Training Commission
National Deputy Head, TVET Sector Support Programme, Deutsche Gesellschaft für Internationale Zusammenarbeit (GIZ) GmbH

Layout & design

SAP Communications

Photo Credits

TVET Sector Support Programme

URL links

Responsibility for the content of external websites linked in this publication always lies with their respective publishers. TVET Sector Support Programme expressly dissociates itself from such content.

This document has been produced with the technical assistance of the TVET Sector Support Programme, which is funded by the European Union, the Federal Republic of Germany and the Royal Norwegian Embassy and has been commissioned by the German Federal Ministry for Economic Cooperation and Development (BMZ). The Deutsche Gesellschaft für Internationale Zusammenarbeit (GIZ) GmbH in close collaboration with the National Vocational and Technical Training Commission (NAVTTTC) as well as provincial Technical Education and Vocational Training Authorities (TEVTAs), Punjab Vocational Training Council (PVTC), Qualification Awarding Bodies (QABs) and private sector organizations.

Document Version

June, 2019

Islamabad, Pakistan

INDUSTRIAL GARMENT EXPERT



LEARNER GUIDE

National Vocational Certificate Level 2

Version 1 - June, 2019

Introduction

Welcome to your Learner's Guide for the Industrial Garment Expert Level-2 "Industrial stitching machine operator". It will help you to complete the program and to go on to complete further study or go straight into employment.

The Industrial Garment Expert program is to engage young people with a program of development that will provide them with the knowledge, skills and understanding to start this career in Pakistan. The program has been developed to address specific issues, such as the national, regional and local trends, markets, the manpower availability within the country, and meeting and exceeding the needs and expectations of their employers / customers.

The main elements of your learner's guide are:

- **Introduction:**
 - This includes a brief description of your guide and guidelines for you to use it effectively
- **Modules:**
 - The modules form the sections in your learner's guide
- **Learning Units:**
 - Learning Units are the main sections within each module
- **Learning outcomes:**
 - Learning outcomes of each learning units are taken from the curriculum document
- **Learning Elements:**
 - This is the main content of your learner's guide with detail of the knowledge and skills (practical activities, projects, assignments, practices etc.) you will require to achieve learning outcomes stated in the curriculum
 - This section will include examples, photographs and illustrations relating to each learning outcome
- **Summary of modules:**
 - This contains the summary of the modules that make up your learner's guide
- **Frequently asked questions:**
 - These have been added to provide further explanation and clarity on some of the difficult concepts and areas. This further helps you in preparing for your assessment.
- **Multiple choice questions for self-test:**

These are provided as an exercise at the end of your learner's guide to help you in preparing for your assessment.

INDUSTRIAL GARMENT EXPERT



© TVET SSP

Module-3

LEARNER GUIDE

National Vocational Certificate Level 2

Version 1 - June, 2019

Modules

Module 1: Maintain Safe Work Environment

Objective of the module: This Competency Standard identifies the competencies required to apply Occupational Safety and Health (OSH) at workplace in accordance with the organization's approved guidelines and procedures. You will be expected to identify and use Personal Protective Equipment (PPE) according to the job requirement and potential hazards at workplace. The underpinning knowledge regarding OSH will be sufficient to provide the basis for your work.

Duration: 100 hours **Theory:** 20 hours **Practical:** 80

Learning Unit	Learning Outcomes	Learning Elements	Materials Required
LU1: Identify Hazards at Workplace	<p>The trainee will be able to:</p> <p>Read and interpret work processes and procedures correctly to identify risk of hazards at workplace</p> <p>Recognize engineering processes, tools, equipment and consumable materials that have the potential to cause harm</p> <p>Identify any potential hazards and take appropriate action to minimize the risk</p>	<p>The importance of safety procedures at workplace at garment industry.</p> <p>Briefing the team about risks factors regarding to safety during working at garment industry especially respiratory system.</p> <p>Knowledge of tools and equipments used for safety purposes.</p> <p>Reviewing the safety precautions signs and posters placed at the walls of the garment industry.</p>	<p>First Aid box</p> <p>PPEs</p>
LU2: Apply Occupational Safety and Health (OSH)	<p>The trainee will be able to:</p> <p>Work safely at all times, complying with health and safety precautions, regulations and other relevant guidelines</p> <p>Identify health and safety hazards at the workplace, so</p>	<p>Application of PPEs required for garment industry for protection as:</p> <ul style="list-style-type: none"> - Respiratory protection - Eye protection - Hearing protection - Hand protection <p>Knowledge of hazards addressed by protective equipment include: physical, electrical, heat, biohazards, and airborne particulate matter.</p>	<p>First Aid Box</p> <p>Fire extinguisher</p> <p>Fire blanket</p> <p>Fire hose reel</p> <p>Nose cover</p> <p>Equipment for</p>

	<p>that the potential for personal injury, damage to equipment or the workplace is prevented, and corrective action is taken</p> <p>Deal with problems which are within your control, and report those that cannot be resolved to the safety officer</p> <p>Identify, Wear, adjust and maintain Personal Protective Equipment to ensure correct fit and optimum protection in compliance with company procedures</p> <p>Keep work area clean and clear of obstructions, and storing tools or equipment, so that the potential for accident or injury is prevented</p>	<p>Communicating within team and safety officer if any unwanted thing occurs during working regarding safety measures.</p> <p>Importance and using of First Aid box in emergency situations. Knowledge of ensuring the date of expiry of medicines available in the first aid box.</p> <p>The importance of clean workplace and its advantages to the personal health. Knowledge of proper place for tools and equipment used at workplace.</p> <p>Importance and Types / classes of fire extinguisher.</p>	<p>contacting safety staff (Telephone)</p> <p>Smoke detecting alarm</p>
--	---	---	---

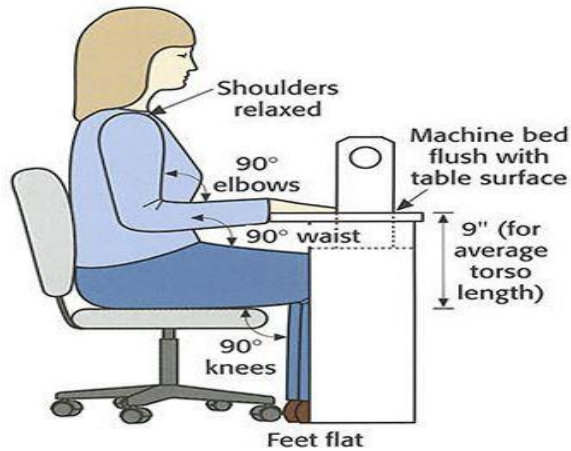

Ergonomics of machine sewing

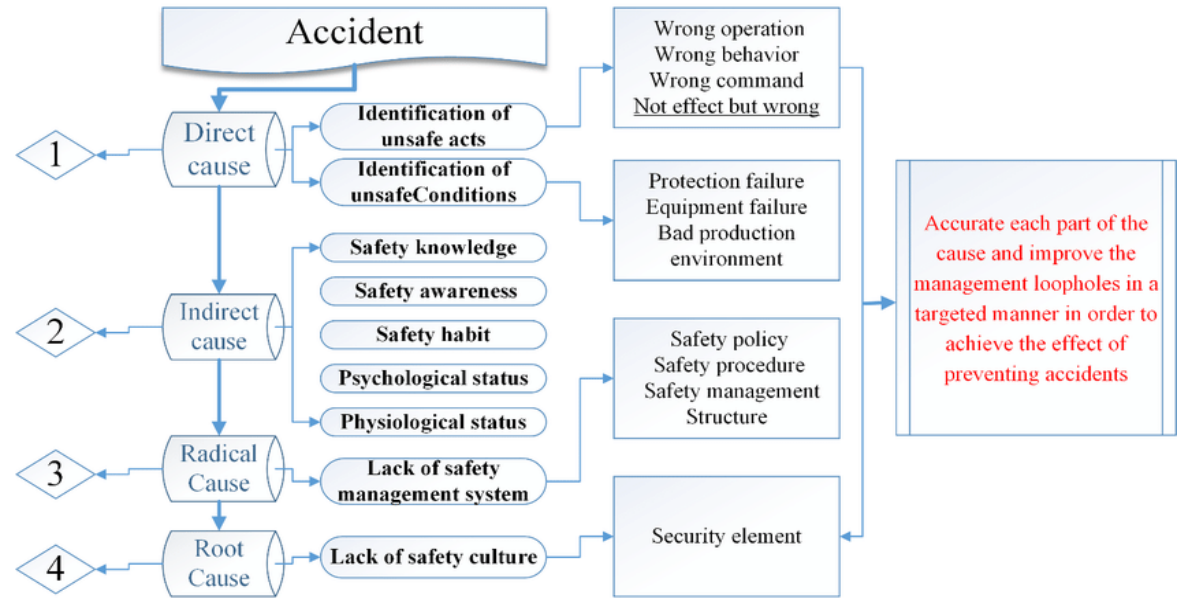

Source: https://www.researchgate.net/figure/Accident-causes-analysis-flow-chart-Author-Contributions-Conceptualization-GF-and_fig3_330890209



First Aid Kit Checklist

- | | |
|---|---|
| <input type="checkbox"/> First aid manual | <input type="checkbox"/> Tylenol |
| <input type="checkbox"/> Bandages (different sizes) | <input type="checkbox"/> Motrin |
| <input type="checkbox"/> Gauze (different sizes) | <input type="checkbox"/> Benadryl |
| <input type="checkbox"/> Ace wraps | <input type="checkbox"/> Hydrocortisone cream |
| <input type="checkbox"/> Tape | <input type="checkbox"/> Triple antibiotic ointment |
| <input type="checkbox"/> Tweezers | <input type="checkbox"/> Hydrogen peroxide |
| <input type="checkbox"/> Nail clippers | <input type="checkbox"/> Aloe |
| <input type="checkbox"/> Scissors | <input type="checkbox"/> Calamine lotion |
| <input type="checkbox"/> Antiseptic wipes | <input type="checkbox"/> Syringes for oral medication |
| <input type="checkbox"/> Instant cold compresses | <input type="checkbox"/> Thermometer |
| <input type="checkbox"/> Tweezers | <input type="checkbox"/> Nasal bulb suction |
| <input type="checkbox"/> Pairs of non-latex gloves | |
| <input type="checkbox"/> Safety pins | |
| <input type="checkbox"/> Tooth preservation kit | |
| <input type="checkbox"/> Splint | |
| <input type="checkbox"/> Flashlight | |
| <input type="checkbox"/> Blanket | |
| <input type="checkbox"/> Contact lenses, saline, and case | |

Video:

Garment Worker training Animation video: Occupational Health and Safety, Energy and Environmental Management.

For Video please visit:

<https://www.youtube.com/watch?v=xoGk8RWqFKw>



Compliance Check List for safe working environment at Garment Industry

A. Health & Safety	B. Fire Safety Related documents
01. PPE (Musk, Scissor, Cutter, knife,Vomor, Eye Safety Glass, Hand Gloves, Metal hand Gloves, Goggles, Ear Muff.	01. Fire Drill register
02. Apron.	02. Fire Fighting Equipment Register.
03. Broken Needle & Broken Needle Register.	03. Fire Fighting Training Register.
04. Exhaust Fan (Ventilation)	04. Fire Fighter Certificate holder.
05. Needle Guard	05. Fire Extinguisher Check.
06. Toilet & Toilet Check List (Soap, Towel)	06. Water Hose Pipe Check.
07. Neat & Cleanliness	07. Fire Fighting Equipment Check (Fire bucket. Water jar, fire Biter, Fire Hook, Stretcher, Respiratory Musk, roof, Lock Cutter , Hammer Heat Proof Gloves)
08. Paddle Rubber Mat.	08. Aisles & Arrow Marking
09. Rubber Mat (Iron man)	09. Fire Extinguisher Marking
10. DB Board-(Ebonite Sheet, Rubber Mat)	10. Fire Evacuation Plan.
11. Pure Drinking Water	11. Exit List Box (with all room where work minimum 10 persons)
12. Spot Removing Room (Exhaust Fan, PPE, MSDS-833/ Action Instruction	12. All fire Safety Related sign (poly & Neon Sign)
13. Machine Hazard.	
14. Workers Work Station blocks.	
15. Garments, fabric, Finished Carton, accessories in the floor.	
16. General Safety Instruction.	
17. First Aid Box.	
18. Loose cable.	
19. Steam Line.	
20. Electrical wiring covers of iron.	
21. Work Station Marking/sign Attach.	
22. Safety Height Limit.	
23. Production Floor Temperature.	
24. Emergency Exit.	
25. User Identification in tag Gun.	
26. Spittoon.	
27. Floor & Wall Painting.	
28. Pest control Register.	
29. Pulley Guard Needle Guard	
30. Smoke Detector.	
31. Housekeeping.	
32. Idle machine Area Segregate.	
33. DB board-Danger sign, Rubber mat.	

Source: <https://garmentspedia.blogspot.com/2015/11/bsci-audit-checklist.html>

Main types of portable extinguishers, their uses and colour coding

WATER

For wood, cloth, coal, plastics, paper, textile, and other solid material fires.



NOT SUITABLE FOR all other types of fires.

POWDER

For solid material, liquid, gas, and electrical fires.



NOT SUITABLE FOR chip or fat pan fires or metal fires (unless it is M28 or L2)

FOAM

For solid material and liquid fires.



NOT SUITABLE FOR gas, metal, electrical, or chip and fat pan fires.

CARBON DIOXIDE (CO₂)

For liquid and electrical fires.



NOT SUITABLE FOR gas, metal, or chip and fat pan fires.

WET CHEMICAL

For fires that involve cooking oils and fats.



NOT SUITABLE FOR other types of fires (use a more appropriate extinguisher).

For more detailed information, please visit <https://www.highspeedtraining.co.uk/hub/fire-safety-signs/>

INDUSTRIAL GARMENT EXPERT



© TVET SSP

Module-2

LEARNER GUIDE

National Vocational Certificate Level 2

Version 1 - June, 2019

Module 2: Operate single needle lock stitching machine

Objective of the module: This competency standard covers the skills and knowledge required to prepare machine for sewing and operate Single needle lock stitching machine for production of required garments.

Duration: 140 hours **Theory:** 28 hours **Practical:** 112 hours

Learning Unit	Learning Outcomes	Learning Elements	Materials Required
LU1:Prepare machine for sewing	<p>The trainee will be able to:</p> <p>Prepare workstation for single needle lock stitch.</p> <p>Follow safety precautions as per SOP / manual.</p> <p>Check machine parts as per guidelines.</p> <p>Select sewing needle and sewing thread according to the sewing operation and the fabric in use</p> <p>Select sewing guides according to sewing operation (use of various sewing feet or sewing guides)</p> <p>Arrange material for sewing operations.</p> <p>Check Stitch per Inch (SPI) and quality on rough fabric for verifying quality for production.</p>	<p>Importance of setting of workbench and seating up according to OH&S practices.</p> <p>Cleaning of machine according to standards for operating the single needle lock stitching machine.</p> <p>Identifying the needle/needle guides and parts / attachments required for sewing the product.</p> <p>Importance of Stitches per Inch (SPI) and verify the SPI on rough fabric to ensure the correct setting of SPI for production.</p> <p>Importance of oil level on machine for proper machine running during production.</p> <p>Knowledge of machine threading and ability to adjust and thread tensions with proper guidance.</p> <p>Identifying the difference between bobbin thread and needle thread.</p> <p>Determining the Set up and wind bobbin threading and inserting the bobbin case.</p> <p>Importance of sewing guides and use of various presser foot; like high shank, low shank, slant shank and Snap-On.</p>	<p>Single Needle Lock Machine</p> <p>Thread Cones</p> <p>Bobbin</p> <p>Bobbin Case.</p> <p>Needle. (DB1)</p> <p>Machine Oil</p> <p>Fabric.</p> <p>Clipper</p> <p>Tool Box</p> <p>Measuring Tape</p>

<p>LU2:</p> <p>Perform sewing operation with single needle lock stitch machine for production</p>	<p>The trainee will be able to:</p> <p>Execute machine control exercise.</p> <p>Perform sewing operations as per product requirement.</p> <p>Take corrective measure for faults occur during sewing if required.</p> <p>Complete target as per given time frame.</p> <p>Review sewing operation randomly.</p>	<p>Operational knowledge of single needle lock stitch for sewing the product with required parameters.</p> <p>Knowledge of machine speed and proper handling of machine according to the type of operations, fabrics and product type.</p> <p>Types of Stitches and stitch classes.</p> <p>Types and classes of seam and their importance.</p> <p>Understanding the single cycle.</p> <p>Conducting sewing operation as per requirement / target and compare it with standard.</p> <p>Identifying types of possible stitch defects during the operations of single needle lock stitch machine and their remedies.</p>	<p>Single Needle Lock Machine.</p> <p>Thread Cones.</p> <p>Bobbin</p> <p>Bobbin Case.</p> <p>Needle.</p> <p>Machine Oil.</p> <p>Fabric.</p> <p>Scissor</p> <p>Clipper.</p> <p>Seam Ripper</p>
<p>LU3:</p> <p>Clean workstation</p>	<p>The trainee will be able to:</p> <p>Clean machine after closing the job.</p> <p>Cover machine for safety.</p> <p>Collect and store waste as per company's policy.</p> <p>Put all tools in tool box.</p>	<p>The importance of housekeeping when the job is completed and covers the sewing machine with guided covering material.</p> <p>Ensuring all the tools and equipment are well placed in appropriate location.</p> <p>Knowledge of wastage and its proper place to dispose off.</p>	<p>Duster</p> <p>Machine cover</p> <p>Dust Bin</p> <p>Cleaning Brush</p> <p>Blower</p>

Examples and illustrations



Industrial Single Needle Stitching Machine

- Max. Sewing Speed: 5500 stitches/minute
- Max. Stitch Length: 5mm
- Unit dimensions (LxWxH): 48 inches by 20 inches by 48 inches
- Needle: DB X 1, sizes 9-18
- 110V with quiet servo motor

Source: <https://www.amazon.com/DDL-8700-Single-Needle-assembly-required/dp/B009EZNPXM>

Anatomy of a Sewing Machine Needle

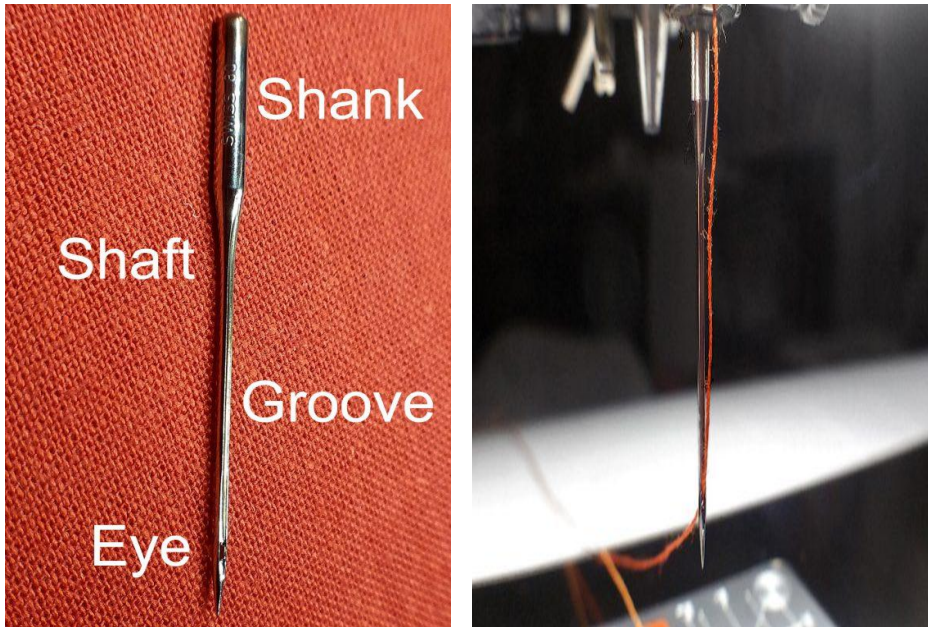

A sewing machine needle looks simple but has many different parts.

The shank is the part that seats into your sewing machine; the flat side usually goes towards the back, and the rounded side towards the front. Some specialty needles may have a completely round shank.

The shaft is the part of the needle that tapers down from the shank.

The groove runs in the front of the needle to the eye. The thread is seated securely in this groove when the needle penetrates the fabric. You can feel the groove by passing your fingernail over the front of the needle.

The eye of the needle is where the thread passes from the front to the back. Different types of needles will have different types of eyes.

The scarf is located on the BACK of the needle, and is a smooth indentation behind the eye. You can easily find the scarf with your finger. The scarf is where the hook passes to pick up the top thread from the needle to pass it around the bobbin to create a lock stitch, and can be shaped differently on various types of needles.

The point is the first part of the needle to penetrate the fabric. Different types of needles will have different points engineered to work best with specific kinds of fabrics.

For more details please visit:

<https://weallsew.com/all-about-sewing-machine-neededes/>

Needle type
(fabric/application)

- Universal
- Stretch
- Jersey / Embroidery
- Jeans
- Leather
- Microtex
- Quilting
- Embroidery
- Metafil
- Topstitch
- Fine Fabrics
- Hemstitch
- Double Eye
- Overlock



Needle size
(fabric/thread)

NM	SIZE
120	19
110	18
100	16
90	14
80	12
75	11
70	10
60	8

Needle type	Needle eye	Needle point
H UNIVERSAL		
H-S		
H SUK		
H-E		
H METAFIL		
H-J		
H-Q		
H-LR		

Stitching Phenomena

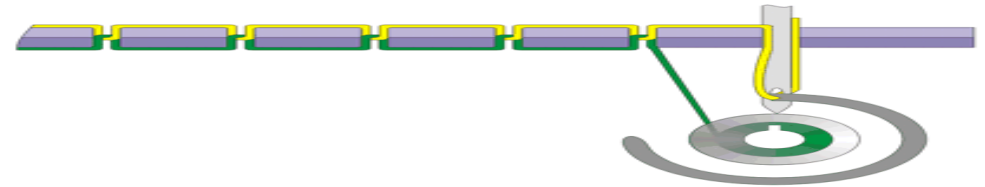
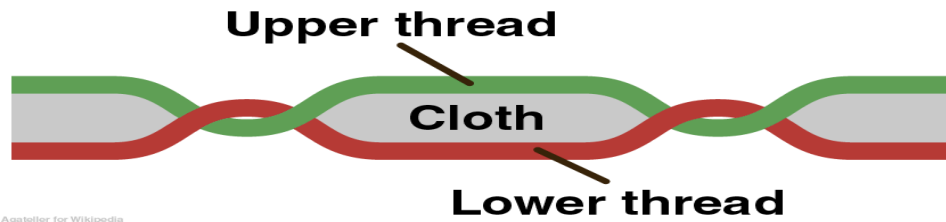

Source: https://en.wikipedia.org/wiki/Lockstitch#/media/File:Lockstitch_-_Anthony_Atkielski.png

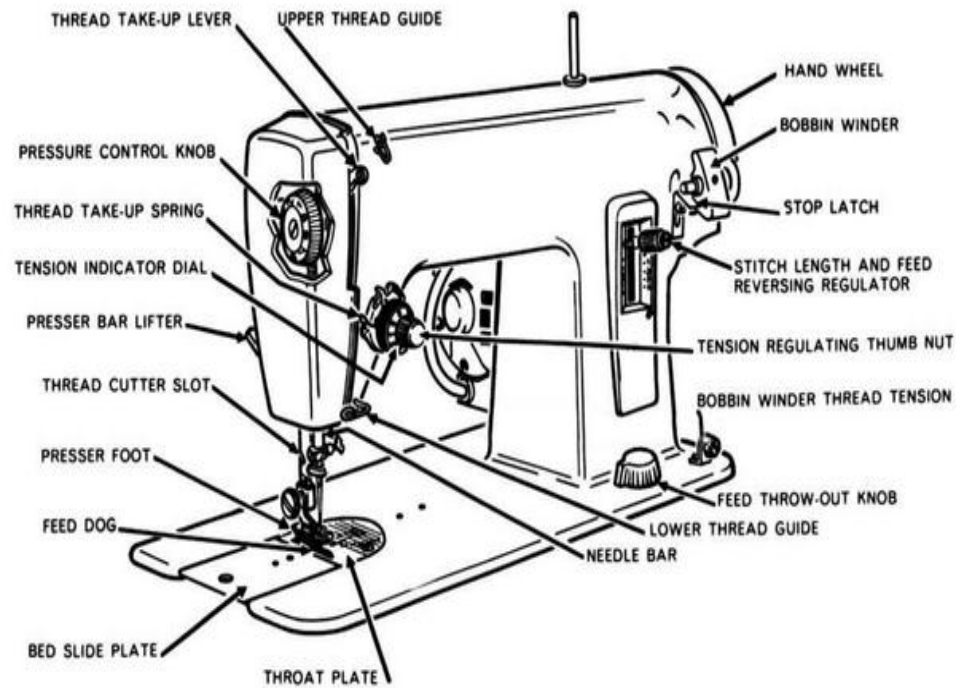
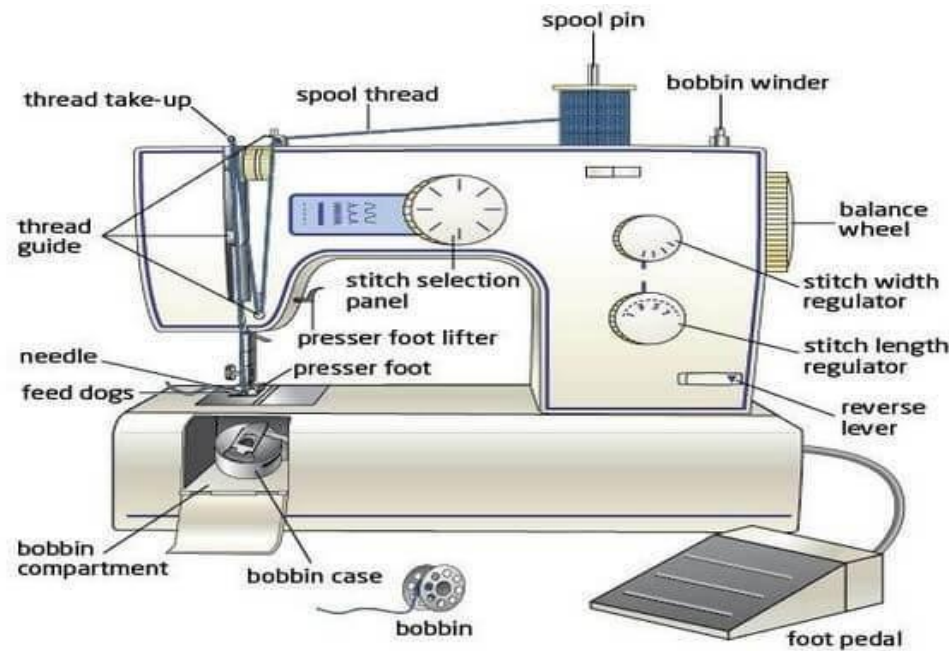

Source: <https://www.quora.com/What-are-the-most-important-upper-parts-of-a-sewing-machine>

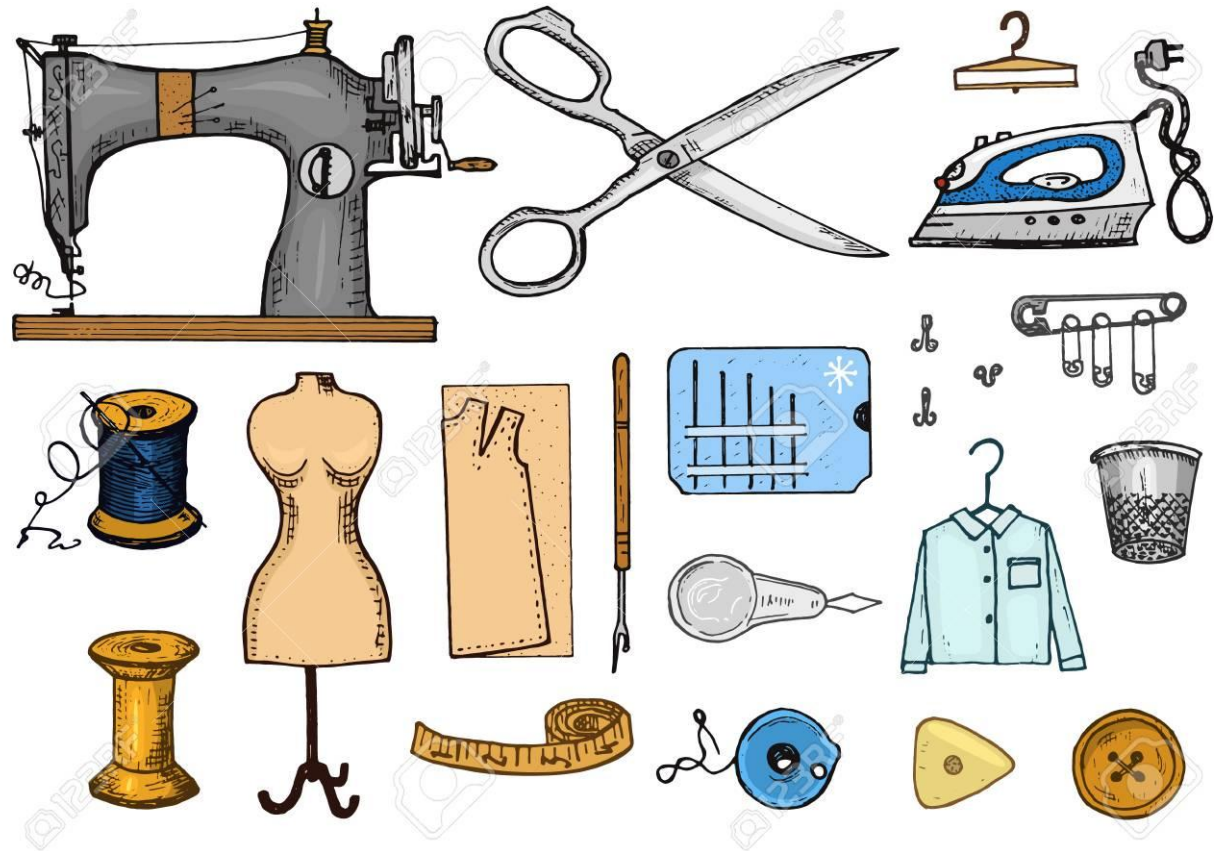

Sewing Tools

SEWING SAFETY

Keep your eyes on your work!

Keep long hair tied up.



Hold the needle correctly and safely.

Keep your fingers away from the needle when using a sewing machine.

Don't talk, or you'll get distracted.

Ask an adult if you are unsure!

Videos:

	<p>Threading Guide for Juki DDL-8700 Single Needle Machine – ABC Sewing Machine</p> <p>For Video please visit:</p> <p>https://www.youtube.com/watch?v=gedBB3B2sso</p> <p>Duration of Video: 00:05:33</p>
	<p>Preparing to oil the sewing machine (9 steps)</p> <p>For Video please visit:</p> <p>https://www.wikihow.com/Oil-a-Sewing-Machine</p> <p>Cancel</p>

INDUSTRIAL GARMENT EXPERT



© TVET SSP

Module-3

LEARNER GUIDE

National Vocational Certificate Level 2

Version 1 - June, 2019

Module 3: Operate double needle lock stitching machine

Objective of the module: This competency standard covers the skills and knowledge required to prepare machine for sewing and operate double needle lock stitching machine for production of required garments.

Duration: 100 hours **Theory:** 20 hours **Practical:** 80 hours

Learning Unit	Learning Outcomes	Learning Elements	Materials Required
LU1. Prepare machine for sewing	The trainee will be able to: Prepare workstation for double needle lock stitch. Follow safety precautions as per SOP / manual. Check machine parts as per guidelines. Select sewing needle and sewing thread according to the sewing operation and the fabric in use Arrange material for sewing operations. Check Stitch per Inch (SPI) and quality on rough fabric for verifying quality for production.	Importance of setting of workbench and seating up according to OH&S practices. Cleaning of machine according to standards for operating the single needle lock stitching machine. Identifying the needle/needle guides and parts / attachments required for sewing the product. Importance of Stitches per Inch (SPI) and verify the SPI on rough fabric to ensure the correct setting of SPI for production. Importance of oil level on machine for proper machine running during production. Knowledge of sewing threads and ability to adjust and thread tensions with proper guidance. Also knowledge and difference between bobbin thread and needle thread. Determining the Set up and wind bobbin threading and inserting the bobbin case. Importance of sewing guides and use of various Presser foot; like high shank, low shank, slant shank and Snap-On.	Double Needle Lock Machine Thread Cones Bobbin Needle Machine Oil. Fabric Clipper Tool Box
LU2. Perform sewing operation by double needle	The trainee will be able to: Execute machine control	Operational knowledge of double needle lock stitch for sewing the product with required parameters. Knowledge of machine speed and proper handling of machine	Double Needle Lock Machine. Thread Cones.

<p>lock stitch machine for production</p>	<p>exercise.</p> <p>Perform sewing operations as per requirement.</p> <p>Take corrective measure for faults occur during sewing if required.</p> <p>Complete target as per given time.</p> <p>Review sew operation randomly.</p>	<p>according to the type of operations, fabrics and product type.</p> <p>Types of Stitches and stitch classes.</p> <p>Types and classes of seam and their importance.</p> <p>Understand the single cycle.</p> <p>Conducting sewing operation as requirement \target and compare it with standard.</p> <p>Identifying types of possible stitch defects during the operations of flat lock chain stitch machine and their remedies.</p>	<p>Bobbin.</p> <p>Needle.</p> <p>Machine Oil.</p> <p>Fabric.</p> <p>Scissor.</p> <p>Clipper.</p> <p>Seam Ripper.</p>
<p>LU3. Clean workstation</p>	<p>The trainee will be able to:</p> <p>Clean machine after closing the job.</p> <p>Cover machine for safety.</p> <p>Collect and store waste as per company's policy.</p> <p>Put all tools in tool box.</p>	<p>The importance of housekeeping when the job is completed and covers the sewing machine with guided covering material.</p> <p>Ensuring all the tools and equipment are well placed in appropriate location.</p> <p>Knowledge of waste and its proper place to dispose off.</p>	<p>Duster.</p> <p>Machine cover.</p> <p>Tool Box.</p> <p>Dust Bin.</p> <p>Cleaning Brush.</p> <p>Blower.</p>



Source: <https://www.indiamart.com/proddetail/computerized-double-needle-sewing-machine-6212370297.html>



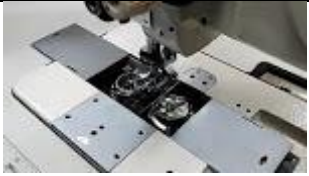

Duration: 00:08:51

THOR GC-1560 Double Needle Walking Foot Sewing Machine Threading

Winding Bobbins and Threading the THOR GC-1560 Double Needle Walking Foot Sewing Machine.

For Video please visit:

<https://www.youtube.com/watch?v=4rKbIXfBo04>

INDUSTRIAL GARMENT EXPERT



© TVET SSP

Module-4

LEARNER GUIDE

National Vocational Certificate Level 2

Version 1 - June, 2019

Module 4: Operate over lock stitching machine

Objective of the module: This competency standard covers the skills and knowledge required to prepare machine for sewing and operate over lock stitching machine for production on garments at 3 to 6 thread safety over lock.

Duration: 70 hours **Theory:** 14 hours **Practical:** 56 hours

Learning Unit	Learning Outcomes	Learning Elements	Materials Required
LU1. Prepare machine for sewing	The trainee will be able to: Prepare workstation for over lock stitch. Follow safety precautions as per SOP / manual. Check machine parts as per guidelines. Select sewing needle and sewing thread according to the sewing operation and the fabric in use Arrange material for sewing operations. Check Stitch per Inch (SPI) and quality on rough fabric for verifying quality for production.	Importance of setting of workbench and seating up according to OH&S practices. Cleaning of machine according to standards for operating the Over lock stitching machine. Importance of Stitches per Inch (SPI) and verify the SPI on rough fabric to ensure the correct setting of SPI for production. Importance of oil level on machine for proper machine running during production. Knowledge of sewing threads and ability to adjust and thread tensions with proper guidance. Also knowledge and difference between lopper thread and needle thread. Determining the Set up and proper threading. Knowledge of checking SPI and control SPI.	Over lock Machine. Thread Cones. Needle.DC27 Machine Oil. Fabric. Clipper. Tool Box. Tweezers
LU2. Perform sewing operation by using over lock stitching	The trainee will be able to: Execute machine control exercise. Perform over lock stitching operations as per requirement Take corrective measure for faults occur during sewing if required.	Operational knowledge of Over lock stitch for sewing the product with required parameters. Knowledge of machine speed and proper handling of machine according to the type of operations, fabrics and product type. Types of Stitches and stitch classes. Types and classes of seam and their importance.	Over lock Machine. Thread Cones. Needle. Machine Oil. Fabric. Scissor.

	<p>Complete target as per given time.</p> <p>Review stitch operation randomly.</p>	<p>Understanding the single cycle.</p> <p>Conducting sewing operation as requirement \target and compare it with standard.</p> <p>Identifying types of possible stitch defects during the operations of over lock stitch machine and their remedies.</p>	<p>Clipper.</p> <p>Seam Ripper.</p> <p>Tweezers</p>
<p>LU3.</p> <p>Clean workstation</p>	<p>The trainee will be able to:</p> <p>Clan machine after closing the job.</p> <p>Cover machine for safety.</p> <p>Collect and store waste as per company's policy.</p> <p>Put all tools in tool box.</p>	<p>The importance of housekeeping when the job is completed and covers the sewing machine with guided covering material.</p> <p>Ensuring all the tools and equipment are well placed in appropriate location.</p> <p>Knowledge of waste and its proper place to dispose off.</p>	<p>Duster.</p> <p>Machine cover.</p> <p>Tool Box.</p> <p>Dust Bin.</p> <p>Cleaning Brush.</p> <p>Blower.</p>

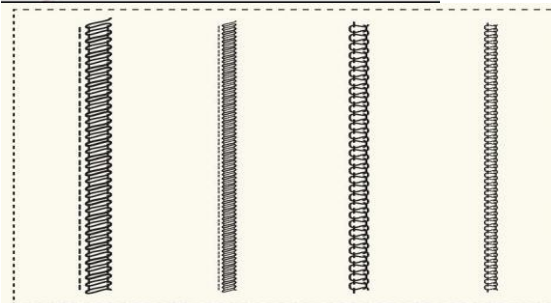
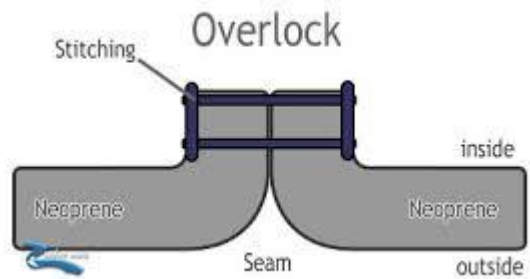

Vectors of Overlock Stitch

Seam classes

According to BS 3870-1:1991, the eight seam classes are following:

- Class 1 – Superimposed seam.
- Class 2 – Lapped seam.
- Class 3 – Bound seam.
- Class 4 – Flat seam.
- Class 5 – Decorative/Ornamental seam
- Class 6 – Edge finishing/neatening seam.
- Class 7 – Applied seam.
- Class 8 – Others.



Fig: Different types of seam



Table 1: types of seam allowance.

types of seam allowance	illustration	seam allowance on a 3D model	seam allowance on a 2D pattern
lap-felled seam			
top stitched seam			
French seam			
zigzag stitched seam			

A TABLE FOR DIFFERENT TYPES OF SEAM & THEIR EXAMPLE

Seam Class-1	Seam Class-2	Seam Class-3	Seam Class-4	Seam Class-7 (Elastic)	Seam Class-8
Two edges are placed together. Then sewing is one alongside edge. Ex- In Seam of Jens.	Edges are placed opposite to each other. Sewing is done one overlapping portion. Ex- In Seam side of Jens or Lungi.	Edges of fabric are bound by a stripe of fabric. Ex- Pocket of pants.	Edges are place side by side & sewn. Ex- Cut & sew garments (decorative)	This seam is produce when additional part such as elastic, lace etc. are attach to the garments. Ex- Attach lace etc.	When the same fabric is folded & sewn. Than this seam class is produce. Ex- Belt Loop, Box Plate of Shirt etc.

Videos:

	00:12:25	<p>No Serger Needed - Learn How To Over lock On A brother Sewing Machine</p> <p>For video please visit: https://www.youtube.com/watch?v=d5SloMFBgJs</p>
	00:01:09	<p>JUKI - MO 6714DA T042S Industrial Over lock Sewing Machine</p> <p>For video please visit: https://www.youtube.com/watch?v=hJhOMbNeskY</p>
	00:05:17	<p>How to sew T-SHIRT part 1 Tutorial . Jak uszyć koszulkę z rozszyciami na okrak</p> <p>For video please visit: https://www.youtube.com/watch?v=zLkNgkzx-wl</p>

INDUSTRIAL GARMENT EXPERT



© TVET SSP

Module-5

LEARNER GUIDE

National Vocational Certificate Level 2

Version 1 - June, 2019

Module 5: Operate flat lock chain stitching machine

Objective of the module: This competency standard covers the skills and knowledge required to prepare machine for sewing and operate flat lock chain stitching machine for production on garments.

Duration: 70 hours **Theory:** 14 hours **Practical:** 56 hours

Learning Unit	Learning Outcomes	Learning Elements	Materials Required
LU1. Prepare machine for sewing	<p>The trainee will be able to:</p> <p>Prepare workstation for flat lock chain stitch.</p> <p>Follow safety precautions as per SOP / manual.</p> <p>Check machine parts as per guidelines.</p> <p>Select sewing needle and sewing thread according to the sewing operation and the fabric in use</p> <p>Arrange material for sewing operations.</p> <p>Check Stitch per Inch (SPI) and quality on rough fabric for verifying quality for production.</p>	<p>The importance of setting of workbench and seating up according to OH&S practices.</p> <p>Cleaning of machine according to standards for operating the single needle lock stitching machine.</p> <p>Identifying the needle/needle guides and parts / attachments required for sewing the product.</p> <p>The importance of Stitches per Inch (SPI) and verify the SPI on rough fabric to ensure the correct setting of SPI for production.</p> <p>The importance of oil level on machine for proper machine running during production.</p> <p>Knowledge of sewing threads and ability to adjust and thread tensions with proper guidance. Also knowledge and difference between lopper thread and needle thread.</p> <p>Determining the Set up and proper threading.</p> <p>The importance of sewing guides and use of various Presser foot like high shank, low shank, slant shank and Snap-On.</p>	<p>Flat lock chain stitching Machine</p> <p>Thread Cones.</p> <p>Needle.(DV-43)</p> <p>Machine Oil.</p> <p>Fabric.</p> <p>Scissor.</p> <p>Clipper.</p> <p>Seam Ripper.</p>
LU2. Perform sewing	<p>The trainee will be able to:</p> <p>Execute machine control</p>	<p>Operational knowledge of flat lock chain stitch for sewing the product with required parameters.</p>	<p>Flat lock chain stitching Machine.</p>

<p>operation by using the flat lock chain stitching</p>	<p>exercise.</p> <p>Perform stitching operations as per requirement.</p> <p>Take corrective measure for faults occur during sewing if required.</p> <p>Complete target as per given time.</p> <p>Review stitching operation randomly.</p>	<p>Knowledge of machine speed and proper handling of machine according to the type of operations, fabrics and product type.</p> <p>Types of Stitches and stitch classes.</p> <p>Types and classes of seam and their importance.</p> <p>Understanding the single cycle.</p> <p>Briefing the team about conduct the sewing operation under the safe environment.</p> <p>Identifying types of possible stitch defects during the operations of flat lock chain stitch machine and their remedies.</p>	<p>Thread Cones.</p> <p>Needle.</p> <p>Machine Oil.</p> <p>Fabric.</p> <p>Scissor.</p> <p>Clipper.</p> <p>Seam Ripper.</p>
<p>LU3. Clean workstation</p>	<p>The trainee will be able to:</p> <p>Clean machine after closing the job.</p> <p>Cover machine for safety.</p> <p>Collect and store waste as per company's policy.</p> <p>Put all tools in tool box.</p>	<p>The importance of housekeeping when the job is completed and covers the sewing machine with guided covering material.</p> <p>Briefing all the tools and equipment placement and their proper location to store for safety purposes.</p> <p>Knowledge of waste and its proper place to dispose off.</p>	<p>Duster.</p> <p>Machine cover.</p> <p>Tool Box.</p> <p>Dust Bin.</p> <p>Cleaning Brush.</p> <p>Blower.</p>

====



Importance of lightening and cleaning the workplace / workstation at garment industry



In the ILO manual, improving working conditions and productivity in the garment industry, it is highlighted that improved lighting in factories have led to as much as 10 per cent productivity improvement with around 30 per cent reduction in errors.

Source: <http://www.apparelviews.com/importance-lighting-garment-factory/>

STITCH TYPES

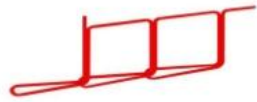

Chain Stitch (blind stitch) –stitch class 101



Lock Stitch – stitch class 301



Zig Zag - 1Step lock stitch –stitch class 404

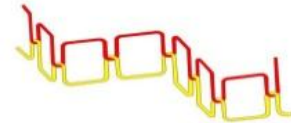

Zig Zag -2Step Lock Stitch –stitch class 304

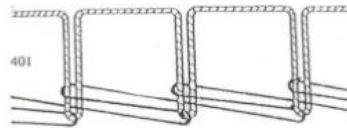

2Thread Chainstitch- 401

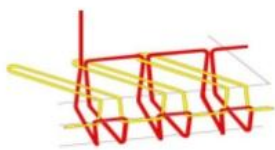

2 Thread Overedge (Single "purl" on edge)
Stitch class 502

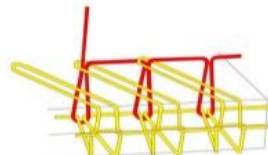

3 Thread Overedge – stitch class 504

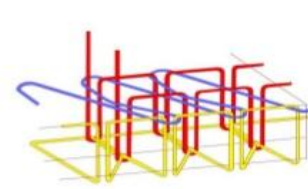

2 Needle 4 Thread Overedge-stitch class-514

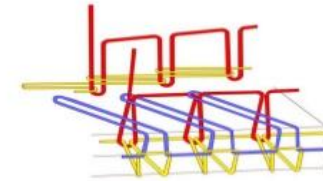

5 Thread Overedge (safety stitch)- stitch class-516



6 Thread Overedgestitch- stitch class-519

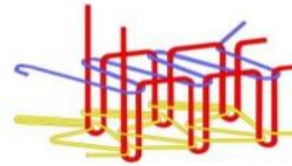

2 Needle 4 Thread Coverstitch-602
(With spader)
2 Needle 3 Thread Coverstitch-606
(Bottom Coverstitch/Without spader)

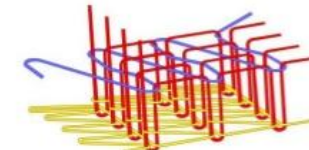



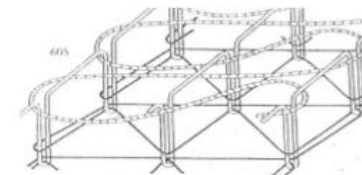

4 Needle 6 Thread Coverstitch (flat seam)-607
4 Needle 6 Thread Coverstitch (flat lock)-607



3 Needle 5 Thread Coverstitch-605
(With spader)

For more valuable information please visit: <https://www.slideshare.net/AmitDas125/industrial-sewing-machines>

Videos:

	00:07:13	<p>Learn to Sew a Flat lock Stitch How to Sew a Flat lock Stitch on your Serger or Over locker – Flat lock Hem with Serger. Video: https://www.youtube.com/watch?v=y0h-iUgKdzk</p>
	00:04:17	<p>How To Create A Flat lock Stitch (Serger / Overlock Machine)</p> <p>https://www.youtube.com/watch?v=HP5hIHLKz_Q</p>
	00:01:37	<p>How to Clean Your Brother Machine Here are some tips from Brother to help you clean your machine safely and efficiently.</p> <p>Video: https://www.youtube.com/watch?v=a1u1bOmjKk8</p>
	00:01:04	<p>Elastic attaching flat lock machine.</p> <p>Video: https://www.youtube.com/watch?v=m47adiKcGMg</p>

INDUSTRIAL GARMENT EXPERT



© TVET SSP

Module-6

LEARNER GUIDE

National Vocational Certificate Level 2

Version 1 - June, 2019

Module 6: Perform product finishing and packaging

Objective of the module: This competency standard covers the skills and knowledge required to cropping, pressing, checking, packing and able to manage stock and able to inspect clock-wise checking of garments.

Duration: 100 hours **Theory:** 20 hours **Practical:** 80 hours

Learning Unit	Learning Outcomes	Learning Elements	Materials Required
LU1. Perform cropping	<p>The trainee will be able to:</p> <p>Crop excess threads without damaging the product to maintain quality.</p> <p>Suck loose threads through vacuum thread sucking machine.</p> <p>Tweak product to separate loose threads.</p>	<p>The importance of cropping the excess thread of the product as per standard to maintain the quality.</p> <p>Understanding the working principle of loose thread sucking machine.</p> <p>Knowledge and importance of tweaking.</p>	<p>Checking Table</p> <p>Clipper</p> <p>Sample for cropping</p> <p>Vacuum sucking machine</p>
LU2. Perform pressing	<p>The trainee will be able to:</p> <p>Prepare workstation for pressing as per requirement.</p> <p>Press product as per requirement.</p>	<p>Briefing about preparing workstation and maintain housekeeping as per policy.</p> <p>Actively support each other to follow the OH&S practices.</p> <p>Types of pressing and their requirement in different circumstances.</p>	<p>Steam Iron</p> <p>Pressing Table</p> <p>Rack</p>
LU3. Perform checking	<p>The trainee will be able to:</p> <p>Inspect clockwise checking for quality as per requirement.</p> <p>Verify product measurement as per spec sheet.</p>	<p>Knowledge and understanding of clockwise inspection.</p> <p>Awareness of possible defects.</p> <p>Performing inspection and record findings.</p>	<p>Product sample</p> <p>DHU format</p> <p>Measurement audit sheet</p>

	<p>Verify product trims and accessories as per spec sheet.</p> <p>Prepare checking report (DHU) on company's standard format.</p>	<p>Ensuring the product measurement as per sample.</p> <p>Ensuring all trims and accessories are as per requirement.</p> <p>Importance of applying DHU and quality report.</p>	<p>AQL Chart</p> <p>Spot Gun</p> <p>Measurement Tape</p> <p>Weighing Scale</p> <p>Camera</p> <p>Defect /Arrow Stickers</p>
<p>LU4. Perform packing</p>	<p>The trainee will be able to:</p> <p>Attach accessories on product as per requirement.</p> <p>Fold product as per spec sheet.</p> <p>Pack product as per spec sheet.</p> <p>Prepare packing list as per specification.</p> <p>Collect rejected product as per quality policy.</p> <p>Identify rejected accessories for dispose-off as per company's policy.</p>	<p>The importance of accessories and its placement.</p> <p>Determining the folding process and its advantages.</p> <p>Knowledge of types of packing.</p> <p>Knowledge of packing list as per job requirement.</p> <p>Importance of separating rejection form A-grade goods and segregate/collect as per policy.</p>	<p>Tag Gun</p> <p>Tag Gun Pins</p> <p>Tape Dispenser</p> <p>Tape</p> <p>Glue Gun</p> <p>Glue Stick</p> <p>Weight Scale</p> <p>Barcode Reader</p> <p>Measurement tape</p> <p>Pallets</p> <p>Packing accessories</p> <ul style="list-style-type: none"> • Hangtags • Price tags • Poly bags • Strings

LU5. Manage stock	<p>The trainee will be able to:</p> <p>Place packed product at warehouse for shipment.</p> <p>Mark packed product for different buyers.</p> <p>Generate report for finished packed products (Bags / cartons)</p>	<p>Understanding the importance of carton stacking.</p> <p>The importance of stack and mark the cartons as per requirements.</p> <p>Generating packed goods reports as per requirements.</p>	<p>Hand Lifter</p> <p>Pallets</p> <p>Tag cards for identification</p>

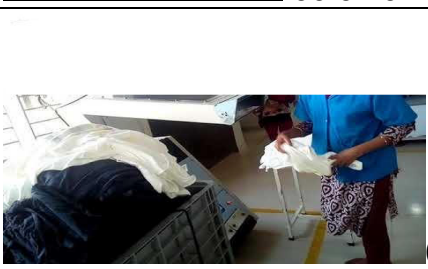
	<p>00:01:04</p>	<p>Thread trimming machine for garment home furnishing</p> <p>Video: https://www.youtube.com/watch?v=QTfjl7jAFJg</p>
	<p>00:00:53</p>	<p>Thread Sucking Machine</p> <p>Video: https://www.youtube.com/watch?v=2fxEZAIQ_vY</p>

Finishing Machines:

Finishing machine for garments is very essential to improve the quality. Factory must have complete department structure with finishing machine comprising of all relevant categories to have smooth operational function. Daily attendance details certified by P.M./Section in charge have been available in each section for management information. Garment finishing machines must be provided with a complete sample for Packing along with all packing trims and approval from Technical department, which is certified by Q.A. Manager.

Finishing:

It is the process of value addition / Improvisation on the garment and making it presentable visually to satisfy the customer's perspective of Good Quality and Appearance. The following processes constitute the Finishing department:

- Thread Trimming
- Inside Checking & Quality Checking
- Ironing
- Top Side Checking, Measurement and Quality Checking
- Attaching Finishing and Packing Trims
- Packing

Each finishing line consists of 1 Supervisor, 4 Inside Q/C's, 4 Topside Q/C's and 1 Hourly Auditor to maintain production as well as quality of the output.

For more details please visit URL:: <https://autogarment.com/finishing-machine-for-garments/>

Videos:

Functions of pressing finishing:

The functions of pressing are

1. To remove the unwanted creases and crush marks
2. To induce creases to the garment based on the design requirement
3. To enable the garment fit to the contour of the body
4. To enable further sewing by preparing the garment for next sewing Operation
5. To finally finish the garment for packing

For more details please visit: <https://clothingindustry.blogspot.com/2017/12/pressing-garment-industry.html>



Valued information about pressing at:

<https://toolsformanufacturing.com/finishing-department-in-garment-industry/>

Finishing Tools, Machines and Equipment for Garment Factories

A garment factory needs to finish its clothes prior to packing and delivering goods to its customer. Their buyers and the end consumers want the finished garments that can directly be displayed on the retail store racks so that the consumers fall in love

with the merchandise after having a look on it.

Let's move to a garment factory, where all garments are made. After stitching, the raw garments are passed through various finishing processes and handled carefully prior to packing.

Finishing activities involved thread trimming, spot cleaning, and ironing, removing dust and loose threads and fibers. For these activities, various finishing tools and equipment are required. Followings are the finishing machines, tools, and equipment used by garment factories. (for more detail visit URL: <https://www.onlineclothingstudy.com/2017/06/finishing-tools-machines-and-equipment.html>)

Inspection		
	Fabric warehouse	Random inspection according to AQL 2.5. If random check becomes fail then require 100% inspection
	Trim & accessories	Random inspection according to AQL 2.5. If random check becomes fail then require 100% inspection
	Cutting Section	Marker checking > Fabric nature and test report check> Test cutting for QA Approval. Fabric spreading > Relaxation if require > Cutting. Sorting (Sticker, Numbering) > bundling. Check or audit cut panels.
	Printing and Embroidery Section	100 % check up of printing panels 100% check up of embroidery panels
	Sewing Section	Inline checkpoint (at vital operation) Random checking (Roaming checking) End of Line checking (apparently 100%) Scrutiny of checked pieces
	Finishing Section	Initial finishing inspection (after wash) Final finishing inspection (After Pressing) Internal shipment inspection
	Valued information at: http://www.goldnfiber.com/2015/01/quality-check-points-in-garment-assembly-process.html	

DHU & DEFECTIVE %

Defects

Defects are all those non-conformance that are not acceptable by end customer. Like imbalanced shape of the garment, broken button or other trims, holes in fabrics, slip stitch, broken seam etc. In a defective garment there may be more than one defect.

Defective Pieces

Defective pieces are those pieces, which are separated for alteration during checking may be for any causes. For the quantitative measure there is two measuring unit as Defects per hundred units and percentage defective.

Defects per hundred units (DHU) – number of total defects in 100 checked garments. The formula for calculating DHU is

$$\text{DHU} = \frac{\text{Total no. of defects found} \times 100}{\text{Total pieces checked}}$$

Percent Defective (%) – total number of defective pieces in 100 checked garments.

$$\text{Percentage defective} = \frac{\text{Total no. of defective pieces} \times 100}{\text{Total pieces checked}}$$

Example: Suppose in a day one table checker checked 200 pieces. He found total 15 defective pieces and in those 15 pieces total 60 defects were found. So, quality measure of that lot in terms of DHU is 30 ($60 \times 100 / 200$) and Percentage Defective is 7.5%.

<https://www.slideshare.net/zamandu/quality-control-58218985>

Inspection Flow chart of Garment Industry

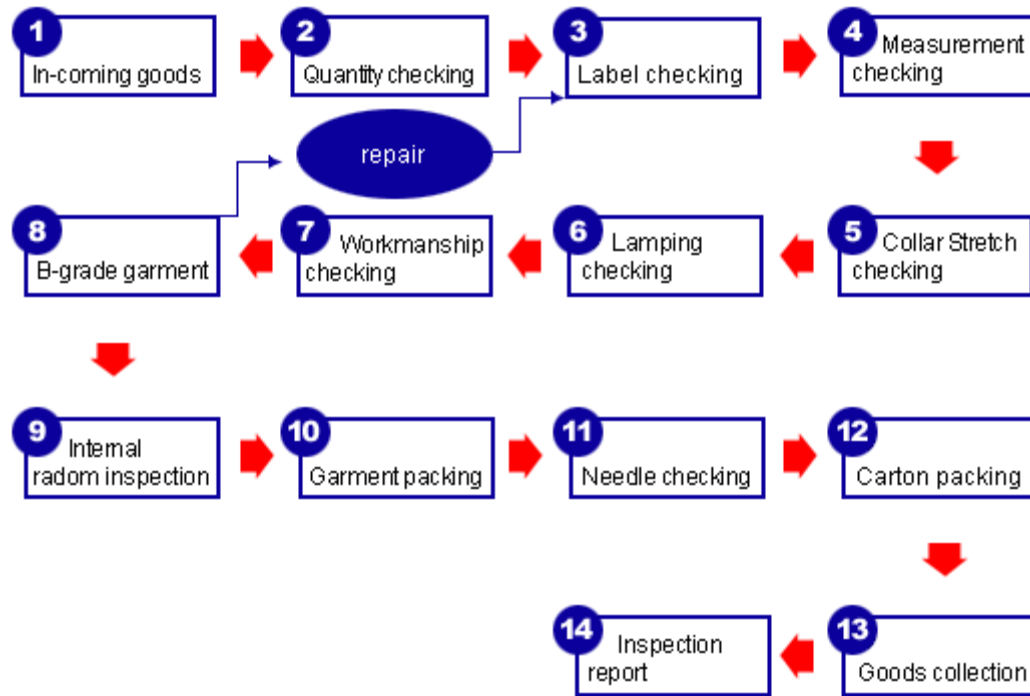

1.



In coming goods - Warehouse

Monthly projection checking and weekly updating with customers/suppliers
All incoming goods will record by computer and scheduling for production

2.



Quantity checking

Basing on incoming goods packing to cross check any +/- quantity by
color/size.



Label checking

Basing on worksheet instruction to full check piece by piece

Record the correct quantity against to incoming total quantity.

Report the data to supplier for (label/tag) replenishment

Stretch test - Random check the main seam of each color/size 2 pieces

i.e. body/shoulder/armpit/opening

4.



Measurement checking

One standard garment compare to another 4 pieces measurement.

And record the defect point by every 10 pieces in general.

5.



Collar stretch checking

All piece of garment has to pass through the standard circle ring test.

6.



Lamping checking

Cross check all piece to find any knitting defects.

7.



workmanship checking

Outlook: compare left and right, color matching/shades, collar shape, position of emb./printing or any special part.

Making: check the knitting/sewing defect on the garment. In case of any particular parts, will assign special person to check.

8.



9.



Procedure: From top (Front+Back) to check the garment as well as inside in anti-clockwise direction.

Under the case of acceptable dye lot, our carton packing section will handle it properly as customer's instruction.

B - grade garment handling

Using special "metal reaction sticker" to specify "un-qualified" garment.

Utilization of color basket

Clear, easily to understand by each single section to process correct procedure (outlook/workmanship/B-grade/re-inspection) during the inspection.

Provide place to manufacturer for repairing work

Internal random checking

Independence department will random check A grade garment from workers before carton packing.

Record the result and report to supervisor daily.

INDUSTRIAL GARMENT EXPERT



© TVET SSP

Module-7

LEARNER GUIDE

National Vocational Certificate Level 2

Version 1 - June, 2019

10.



Garment packing

Subject to customer packing instruction, and pack it one by one in standard cardboard. Extra step to cross check the size before needle check.

11.



Needle detector

Daily machine check at 08 : 00、 12 : 00、 13 : 30、 17 : 30
Ensures proper specimen to check the machine is in good condition.
Records daily test of the machine performance.
Scheduled regular maintenance.

12.



Carton packing

FS will provide the full service of packing in term of carton numbering/ packing requirement with detail packing list. Any particular dye lot or B grade goods is listed for supplier record.
Each carton is sealed with FS logo adhesive tape as well as needle check sticker to specify the carton is in good condition.

13.



Goods collection

FS will contact manufacturer in advance to arrange the goods collection.
FS can offer temperately goods storage by appointment.

14.



Inspection report

FS will furnish inspection reports within the next working day of inspection
by fax / mail to concern parties.
Inspection result is also available through our web-site.

Source: <http://richgrowth.com.hk/aboutus.html>

Module 7: Demonstrate Communication Skills.

Objective of the module:

Duration: 70 hours **Theory:** 14 hours **Practical:**

Learning Unit	Learning Outcomes	Learning Elements	Materials Required
LU1. Adopt effective Listening	The trainee will be able to: Practice active listening. Ask clarifying questions. Listen and empathize with other person.	The importance of effective listening. Types of effective listening like; appreciative, critical, relationship and discriminative listening. Understanding information provided by the teammates or supervisor.	Note book Speakers
LU2. Develop Nonverbal Communication	The trainee will be able to: Adopt hand gestures. Encourage others to speak openly with you. Make eye contact with communicator. Make relaxed, open stance during communication. Perform friendly tone during communication.	Importance of types of non-verbal communications like; Facial expressions, Gestures, Body language, Eye contact, Appearance and Paralinguistic communications. Awareness to how managers, supervisors and teammates communicate with non-verbal communications at workplace. Creating friendly environment during duties performed at workplace to increase the productivity.	Note book Speakers
LU3. Develop verbal communication	The trainee will be able to: Adopt face to face conversations Convey your message clearly and directly. Adopt phrases as simple as	Types of verbal communications and their advantages. Sharing information between individuals by using speech at the workplace. Ensuring that the enunciation, stress and tone of voice with which the words are expressed is appropriate and respect other ideas during	Note book Internet

	demonstrate Respect others and their ideas	meetings.	
LU4. Develop Confidence	The trainee will be able to: Make confidence when you interact others Adopt firm communication but in friendly tone. Demonstrate behavioural skills. Develop sound interpersonal skills Ensure understanding	Showing confidence with positiveness during performs duties at workplace. Knowledge of behavioral skills and adopt these skills at the workplace for creating positive environment. Understanding the others communications when performed duties and tasks at workplace. Developing sound interpersonal skills.	Notebook Internet
LU5. Pick the Right Medium	The trainee will be able to: Convey your message in few words. Convey message through live phone calls. Convey text message through phone. Convey message through WhatsApp. Convey message through email. Convey message through writing.	Types of medium used at workplace for better communications and ability of choosing right medium of communication. Creating teammates groups at whats'up for ideas, suggestions and relevant information. Using telephones, emails ,scanner,faxand text messages for communications with employers, supervisor or customers. Conveying ideas, reports through writing skills with supervisor where it will need.	Notebook:20 Multimedia:01 Internet Computer:05 Mobile phone Scanner Fax Machine Pen Audio System

Module Summary:

Module Title and Aim	Learning Units	Timeframe of modules
<p>Module 1: Maintain safe work environment Aim: The Aim of this module is to follow Occupational Safety and Health (OSH) at work place in accordance with the organization's approved guidelines and procedures. Identify and use Personal Protective Equipment (PPE) according to the job requirement and potential hazards at workplace. The underpinning knowledge regarding OSH will be sufficient to provide the basis for your work.</p>	<p>LU1: Identify Hazards at Workplace LU2: Apply Occupational Safety and Health (OSH)</p>	100
<p>Module 2: Operate single needle lock stitching machine Aim: The aim of this module is to cover the skills and knowledge required to prepare machine for sewing and operate Single needle lock stitching machine for production of required garments.</p>	<p>LU1: Prepare machine for sewing LU2: Perform sewing operation with single needle lock stitch machine for production LU3: Clean workstation</p>	140
<p>Module 3: Operate double needle lock stitching machine Aim: This aim of this module is to cover the skills and knowledge required to prepare machine for sewing and operate double needle lock stitching machine for production of required garments.</p>	<p>LU1: Prepare machine for sewing LU2: Perform sewing operation with double needle lock stitch machine for production LU3: Clean workstation</p>	100
<p>Module 4: Operate over lock stitching machine Aim: The aim of this module is to cover the skills and knowledge required to prepare machine for sewing and operate over lock stitching machine for production on garments at 3 to 6 thread safety over lock.</p>	<p>LU1: Prepare machine for sewing LU2: Perform sewing operation by using over lock stitching. LU3: Clean workstation</p>	70
<p>Module 5: Operate flat lock chain stitching machine Aim: The aim of this module is to cover the skills and knowledge required to prepare machine for sewing and operate flat lock chain stitching machine for production on garments.</p>	<p>LU1: Prepare machine for sewing LU2: Perform sewing operation by using the flat lock chain stitching LU3: Clean workstation</p>	70
<p>Module 6: Perform product finishing and packaging Aim: The aim of this module is to cover the skills and knowledge required to cropping, pressing, checking, packing and able to manage stock and able to inspect clock-wise checking of garments.</p>	<p>LU1: Perform cropping LU2: Perform pressing LU3: Perform checking LU4: Perform packing LU5: Manage stock</p>	100

Module Title and Aim	Learning Units	Timeframe of modules
Module 7: Demonstrate Communication Skills Aim: The aim of this module is to cover the skills and knowledge required to adopt effective Listening, Develop Nonverbal & Verbal Communication, Develop Confidence and Pick the Right Medium.	LU1: Adopt effective listening LU2: Develop nonverbal communication LU3: Develop verbal communication LU4: Develop confidence LU5: Pick the right medium	70

Test Yourself (Multiple Choice Questions)

MODULE 2:	
Question	Candidate's answer
1. Enlist at-least FIVE machine parts of single needle lock stitching machine.	<ul style="list-style-type: none"> • Pressure foot • Knee lifter • Feed dog • Bobbin Winder • Shuttle
2. Define SPI and its effect on product quality?	Number of stitches in one inch is called SPI. Higher the SPI, higher the seam strength.
3. What is the function of single needle lock stitching machine?	To joint two or more panels as per requirements with the help of needle and hook.
4. Define any FIVE stitching faults during sewing operations?	<ul style="list-style-type: none"> i. Skip Stitch ii. Slip Stitch iii. Loose Stitch iv. Broken Stitch v. Puckering

MODULE 2:	
Question	Candidate's answer
5. Define the function of Feed Dog?	Responsible for the forward and backward movement of the fabric.
6. Which needle used in single needle lock stitching machine. a. DBX1 b. DCX27 c. DVX43 d. DPX5	A
7. SPI is the abbreviation of? a. Stitches per inch b. Sewing per inch c. Setting per inch d. Sewing cycles per inch	A
8. How many shuttles are used in single needle lock stitching machine?	There is only one shuttle which is used in single needle lock stitch machine.
9. Which one of the following operations cannot be done on single needle lock stitching machine? A. Pocket attach B. Bottom hemming C. Bar tack D. Flap attach	C

MODULE 2:	
Question	Candidate's answer
<p>10. Which of the following statement is true?</p> <p>a. Tools of machine can be placed at right side of the machine</p> <p>b. Tools of machine can be placed at tool box.</p>	B

MODULE 3:	
Question	Candidate's answer
<p>11. Enlist at-least FIVE machine parts of double needle lock stitching machine.</p>	<ul style="list-style-type: none"> • Pressure foot • Knee lifter • Feed dog • Bobbin Winder • Shuttle
<p>12. Define SPI and its effect on product quality?</p>	<p>Number of stitches in one inch is called SPI. Higher the SPI, higher the seam strength.</p>
<p>13. What is the function of double needle lock stitching machine?</p>	<p>Two adjacent stitches used to joint two or more panels as per requirements with the help of needles and hooks.</p>
<p>14. Define any FIVE stitching faults during sewing operations?</p>	<p>vi. Skip Stitch</p> <p>vii. Slip Stitch</p> <p>viii. Loose Stitch</p> <p>ix. Broken Stitch</p> <p>x. Puckering</p>

MODULE 3:	
Question	Candidate's answer
<p>15. Define the function of Feed Dog.</p>	Responsible for the forward and backward movement of the fabric.
<p>16. Which needle used in double needle lock stitching machine.</p> <p>A. DBX1 B. DCX27 C. DVX43 D. DPX5</p>	D
<p>17. SPI is the abbreviation of?</p> <p>A. Stitches per inch B. Sewing per inch C. Setting per inch D. Sewing cycles per inch</p>	A
<p>18. How many shuttles are used in double needle lock stitching machine?</p>	There are two shuttles which are used in double needle lock stitch machine.
<p>19. Which one of the following operations cannot be done on double needle stitching machine?</p> <p>A. Pocket attach B. Bottom hemming C. Bar tack D. Flap attach</p>	C

MODULE 3:	
Question	Candidate's answer
<p>20. Which of the following statement is true?</p> <p>A. Tools of machine can be placed at right side of the machine</p> <p>B. Tools of machine can be placed at tool box.</p>	B

MODULE 4:	
Question	Candidate's answer
<p>21. Which machine part is not belonged to over lock machine.</p> <p>a. Loppers</p> <p>b. Shuttle</p> <p>c. Cutting Blade</p> <p>d. Paddle</p>	B
<p>22. Define SPI and its effect on product quality?</p>	Number of stitches in one inch is called SPI. Higher the SPI, higher the seam strength.
<p>23. What is the function of over lock machine?</p>	Overlock stitch is used for raw edge cutting and sewing by the help of cutters and loppers.
<p>24. Define any FIVE stitching faults during sewing operations?</p>	<ol style="list-style-type: none"> 1. Skip Stitch 2. Slip Stitch 3. Loose Stich 4. Broken Stitch 5. Puckering

MODULE 4:	
Question	Candidate's answer
<p>25. How many needles are used in 3 thread over lock?</p> <p>a. 4 b. 2 c. 3 d. 1</p>	D
<p>26. Which needle used in over lock machine.</p> <p>a. DBX1 b. DCX27 c. DVX43 d. DPX5</p>	B
<p>27. SPI is the abbreviation of?</p> <p>a. Stitches per inch b. Sewing per inch c. Setting per inch d. Sewing cycles per inch</p>	A
<p>28. How many loppers are used in 3 thread over and 5 thread Over lock?</p>	2 loppers are used in 3 thread overlock and 3 loppers are used 5 thread overlock.
<p>29. Which of the following operation can be done on over lock stitching machine?</p> <p>A. Secure edges B. Pocket attach C. Bar tack D. Flap attach</p>	A

MODULE 4:	
Question	Candidate's answer
<p>30. Which of the following statement is true?</p> <p>A. Tools of machine can be placed at right side of the machine</p> <p>B. Tools of machine can be placed at tool box.</p>	B

MODEL 5:	
Question	Candidate's answer
<p>31. Which machine part is not belonged to flat lock chain stitch machine?</p> <p>A. Loppers</p> <p>B. Shuttle</p> <p>C. Spreaders</p> <p>D. Paddle</p>	B
<p>32. Define SPI and its effect on product quality?</p>	Number of stitches in one inch is called SPI. Higher the SPI, higher the seam strength.
<p>33. What is the function of Flat lock chain stitch machine?</p>	FLCS is mostly used for securing edges and hemming in knit products with the help of spreaders and loppers. This machine can also be used for ornamental stitching.

MODEL 5:	
Question	Candidate's answer
<p>34. Define any FIVE stitching faults during sewing operations?</p>	<ul style="list-style-type: none"> • Skip Stitch • Slip Stitch • Loose Stitch • Broken Stitch • Puckering
<p>35. How many needles can be used in Flat Lock Chain Stitch machine?</p> <p>A. 4 B. 2 C. 3 D. 1</p>	C
<p>36. Which needle used in Flat lock chain stitch machine?</p> <p>A. DBX1 B. DCX27 C. DVX43 D. DPX5</p>	C
<p>37. SPI is the abbreviation of?</p> <p>A. Stitches per inch B. Sewing per inch C. Setting per inch D. Sewing cycles per inch</p>	A
<p>38. How many loppers are used in Flat lock chain stitch machine?</p>	There is only one lopper which is used in Flat lock chain stitch machine.

MODEL 5:	
Question	Candidate's answer
<p>39. Which of the following operation can be done on flat lock chain stitch machine?</p> <p>A. Collar attach B. Hemming C. Bar tack D. Flap attach</p>	B
<p>40. Which of the following statement is true?</p> <p>A. Tools of machine can be placed at right side of the machine B. Tools of machine can be placed at tool box.</p>	B

MODULE 6:	
Question/	Candidate's answer
<p>41. Why is cropping performed?</p>	Its clears the garment from hanging thread, left in stitching
<p>42. What instrument is used in pressing?</p>	Iron Table/ironing board Steamer Boiler

MODULE 6:	
Question/	Candidate's answer
43. What are the rules of checking, how do you determine the checking points	Stitching Size spec/measurement Checking for needle pins cropping
44. Quality inspection is done a) Clock wise b) Anti clockwise c) By microscope d) Following spec sheet/	clockwise
45. What are the three main task of packing	1) Attach accessories 2) Press 3) Fold 4) pack
46. Describe three methods of cropping.	<ul style="list-style-type: none"> • Crop excess threads without damaging the product to maintain quality. • Suck loose threads through vacuum thread sucking machine. • Tweak product to separate loose threads.
47. Where do rejected product placed after checking?	1) List and make a report 2) Sent for re-work 3) Warehoused 4)
48. How is the packed stock managed?	1) Mark buyers name 2) Place product at warehouse for shipment 3) Make a stock report

MODULE 6:	
Question/	Candidate's answer
49. Write the steps of finishing.	a) Cropping b) Pressing c) Folding d) Warehousing
50. Write down names of three trims used on a garment	Thread Zipper Button Hook

